



LEAD MILLS CONSERVATION AREA DESIGN

FOR THE TOWN OF MARBLEHEAD & CITY OF SALEM, MASSACHUSETTS

EMILY BERG, JEFFERY DAWSON & ALLISON RUSCHP

THE CONWAY SCHOOL

SPRING 2014

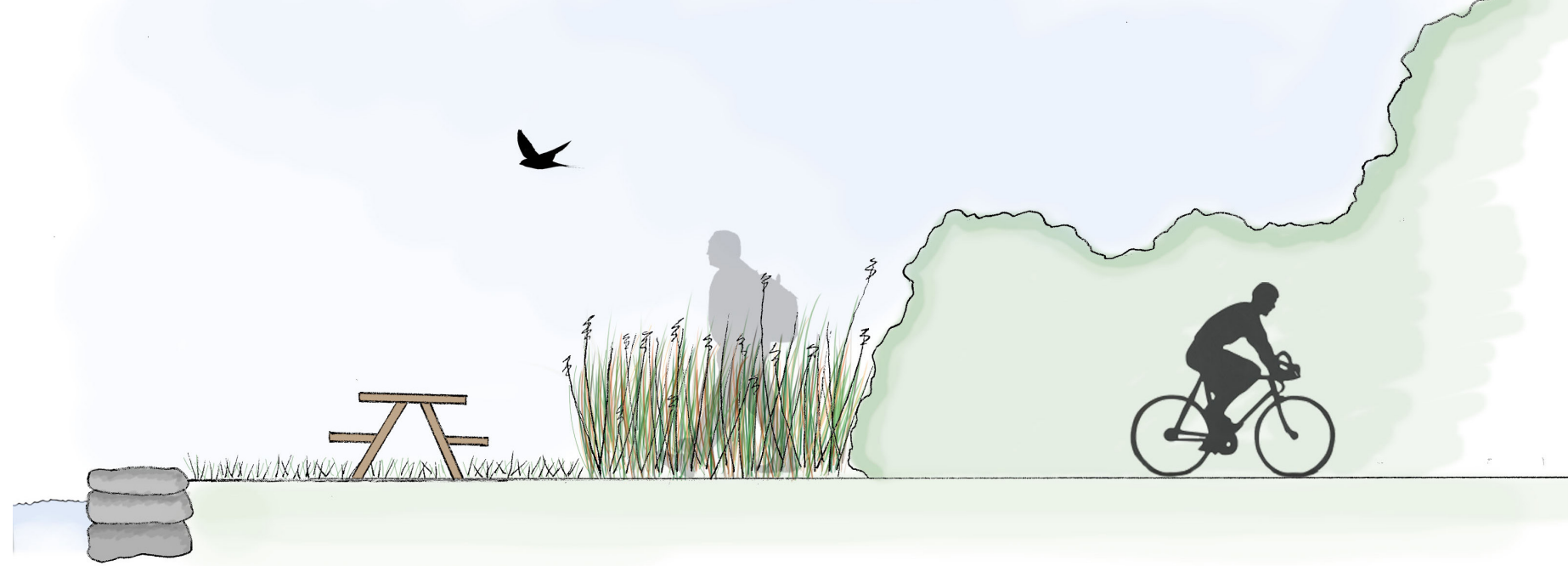

INDEX

CONTEXT.....	1	ALTERNATIVE #1.....	16
EXISTING CONDITIONS.....	2	ALTERNATIVE #2.....	17
COMMUNITY INPUT.....	3	ALTERNATIVE #3.....	18
NEIGHBORS.....	4	FINAL DESIGN.....	19
THE PATH.....	5	DESIGN DETAILS 1.....	20
THE SHORE.....	6	DESIGN DETAILS 2.....	21
UPLAND VEGETATION.....	7	DESIGN DETAILS 3.....	22
ATLANTIC FLYWAY.....	8	GRADING PLAN.....	23
VIEWS.....	9	PLANTING PLAN.....	24
RESTRICTIONS.....	10	PLANTING DETAILS.....	25
ACCESS.....	11	INVASIVE MANAGEMENT.....	26
TOPOGRAPHY.....	12	CONSTRUCTION DETAILS.....	27
REMEDICATION.....	13	SIGN DETAILS.....	28
STORM SURGE.....	14	FENCE DETAILS.....	29
SUMMARY.....	15	COST ESTIMATES.....	30

CONTEXT

Jointly owned by the City of Salem and the Town of Marblehead on the south shore of Salem Harbor, Lead Mills Conservation Area is an opportunity to bridge neighboring communities and build coastal habitat and biodiversity on land that has been heavily impacted by lead contamination and where extensive remediation has taken place.

Lead Mills Conservation Area is 4.5 acres of formerly industrial waterfront property on the south shore of Salem Harbor. The property fronts busy Lafayette Street (Route 114) and Forest River on its west end and Wyman Woods on its east end. The property was jointly purchased by the City of Salem and the Town of Marblehead for conservation and recreation after plans for development were abandoned and heavy remediation of lead contamination was completed. The municipalities seek a design for the park that maintains the current open character, provides universally accessible paths, highlights desirable views, connects to other existing trails, and uses vegetation to potentially address and manage the invasive species and eroding slopes present in places.

The site was used as a grist mill in 1734 before becoming a lead manufacturing plant in 1831. The lead mills produced white lead for a range of products including bullets for the Civil War and pigment for paint. Once a hub for local industry, the lead mills at one time produced 6,000 tons of white lead annually. The lead mills were purchase by Associated Grocers in 1947 who used the buildings for warehousing food products until a fire in 1968 burned the buildings to the ground. After the fire, the site returned to forest and remained unused for decades.



The Lead Mills Conservation Area is a mixed coastal and upland habitat on the south shore of Salem Harbor, and is co-owned by the City of Salem and the Town of Marblehead.

GOAL:

A public waterfront conservation area that has:

- Public open space
- Universally accessible areas
- Highlighted views
- Connections to other trail systems
- Managed invasive species and slope stability
- Parking for six to eight cars with universally accessible spaces
- Access to the shore

Clients

City of Salem & Town of Marblehead
Salem Parks and Recreation Commission
Conservation Commission
Marblehead Conservancy
Essex County Greenbelt

NOT FOR CONSTRUCTION. THIS DRAWING IS PART OF A STUDENT PROJECT AND IS NOT BASED ON A LEGAL SURVEY.

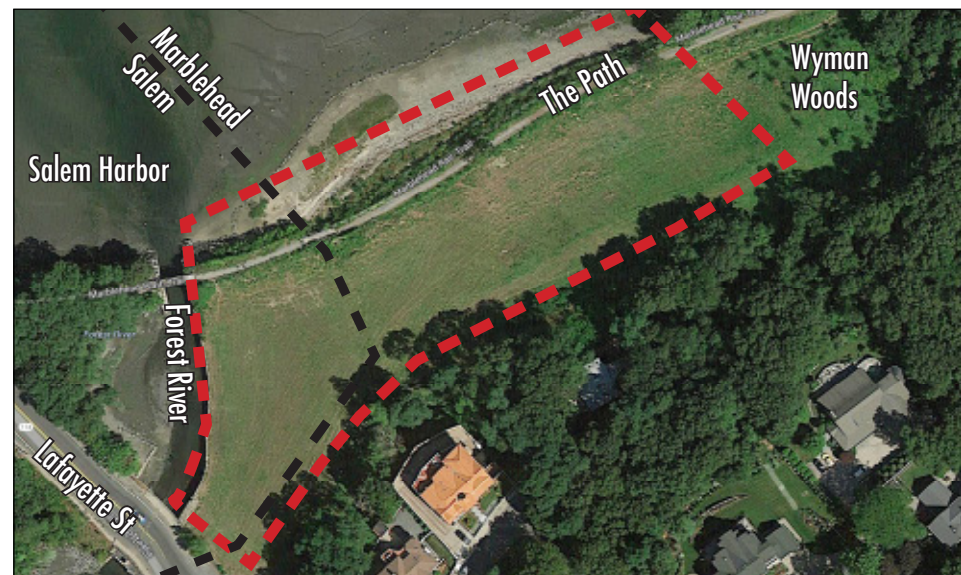

Lead Mills Conservation Area is off busy Lafayette Street (Route 114). Salem Harbor borders it to the north, and a bike path cuts through the northern portion of the property. The town line between Salem and Marblehead also cuts through the property.



Forest River runs past the site to the west, emptying into Salem Harbor. The Forest River wall has no barrier to prevent people from falling in. This photo is taken from the bike path looking back at the Lead Mills Conservation Area.



Lead Mills Conservation Area is one of the only open landscapes in Marblehead and Salem. It connects to nearby conservation land via the bike path. This photo is taken from The Path looking southwest towards Lafayette Street.

EMILY BERG, JEFF DAWSON & ALLISON RUSCHP
THE CONWAY SCHOOL
GRADUATE PROGRAM IN SUSTAINABLE
LANDSCAPE PLANNING & DESIGN
WWW.CSLD.EDU
SPRING 2014

LEAD MILLS
CONSERVATION AREA DESIGN
MARBLEHEAD & SALEM, MA
485 LAFAYETTE STREET, SALEM, MA 01970

CONTEXT

EXISTING CONDITIONS

The Lead Mills Conservation Area site conditions and location make it a prime area for an open landscape connecting the two towns.

NOT FOR CONSTRUCTION. THIS DRAWING IS PART OF A STUDENT PROJECT AND IS NOT BASED ON A LEGAL SURVEY.

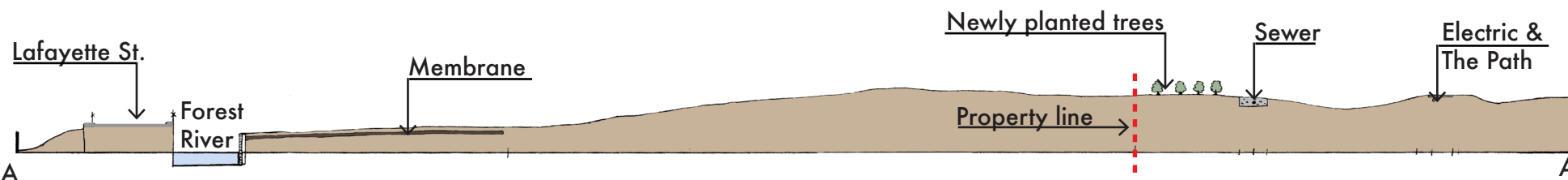
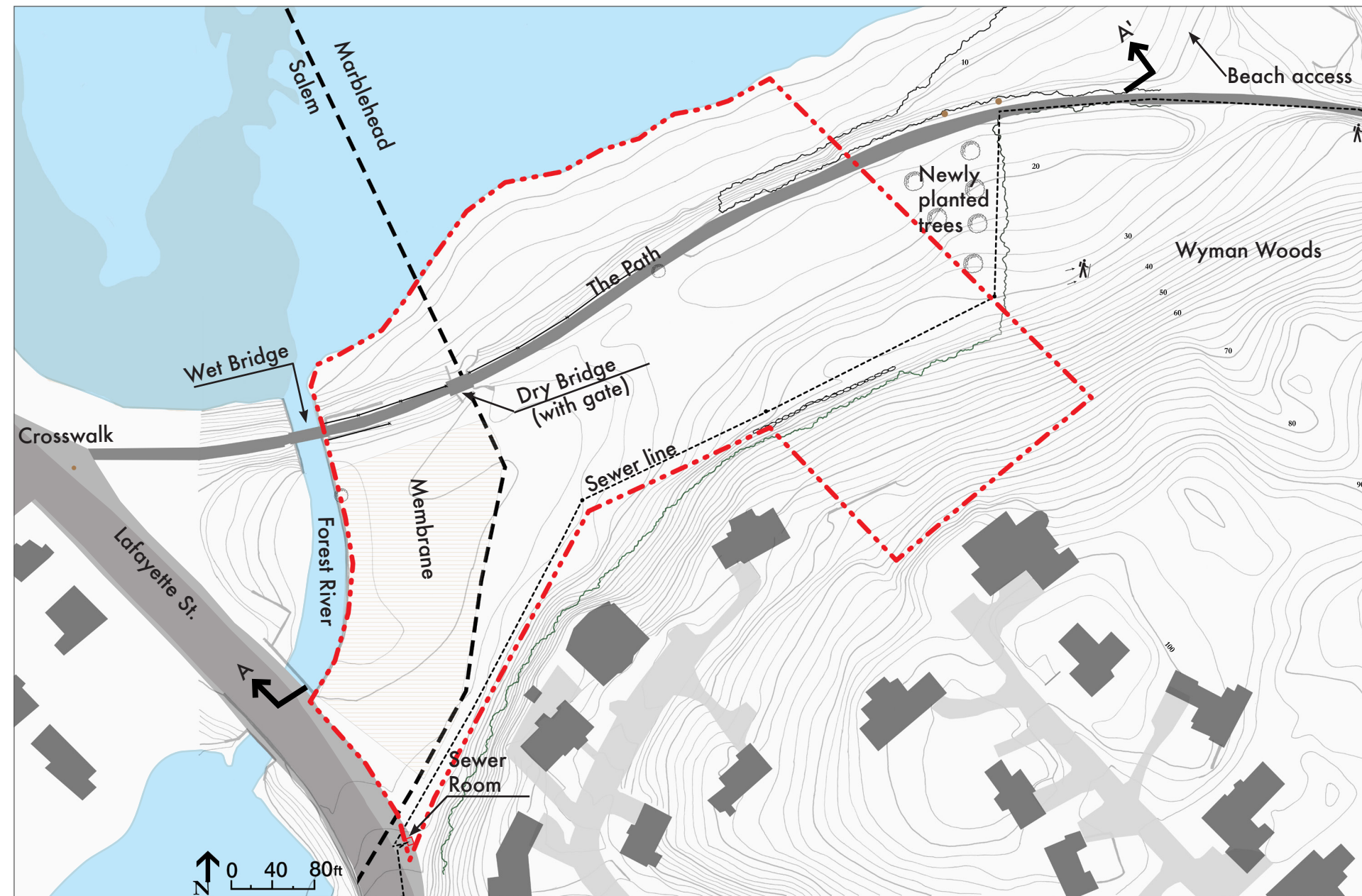

Section across the property shows the gentle slopes, the river wall without a barrier, and the Forest River at mid-tide.

OBSERVATIONS

- The town line divides the property.
- A membrane one foot below the surface covers the remediated soil on the Salem portion.
- A recreation path that connects the two towns runs through the property and covers buried electric utility lines.
- A chain link fence along The Path restricts access and views to the shore.
- Wyman Woods to the east is a forested conservation area with trails for walkers.
- Newly planted maple trees border the property to the east.
- The shore cannot currently be accessed from the site, but there is access just a few hundred yards east on The Path.
- Lafayette Street, which runs along the southwestern property boundary, is a state highway that sees high volumes of traffic each day.
- The Forest River, along the west side of the property, empties into Salem Harbor and provides coastal marsh habitat for many species along its shores.
- A wall with no fence along the Forest River drops down over 15 feet during low tide.
- There is no clearly delineated parking area and people are parking along Lafayette Street to access the site.
- There are worn footpaths through the site which are not universally accessible because of their narrow widths and steep slopes.
- The site is currently inaccessible for wheelchairs.

IMPLICATIONS

- Establish paths that are universally accessible and make the river wall safe.
- Keep stabilized soils capped and undisturbed.
- Explore access areas to the beach/shore.

COMMUNITY MEETING

The majority of residents want to see the Lead Mills Conservation Area become maintained open space that can function independently and symbiotically with its neighboring conservation areas.

NOT FOR CONSTRUCTION. THIS DRAWING IS PART OF A STUDENT PROJECT AND IS NOT BASED ON A LEGAL SURVEY.



Community members gather to discuss their desires for the site.



Town planner Becky Cutting recording community members' ideas about the Lead Mills Conservation Area Design.



Community members debate the future uses of the Lead Mills Conservation Area.



Team member Emily Berg walks community members through the summary analysis of the site.



Marblehead residents discuss the alternatives with team member Allison Ruschp.

The Conway team held two community meetings to get feedback from the community for the Lead Mills Conservation Area. The first meeting, held on May 15, 2014, helped the team understand the community's desires and concerns for the design of the Lead Mills Conservation Area. At the second meeting the team presented three alternative designs for the site in order to collect the community's feedback on the designs and come to a final design.

COMMUNITY'S TOP RATED DESIRES

Participants generated a list and voted on their desires for the conservation area.

- "Use native low-maintenance plants that will prevent invasive species." (10 votes)
- "Do nothing (or next to nothing)." (8 votes)
- "Pedestrian light on Lafayette (electrical wires already in place)." (8 votes)
- "Signage—with a focus on history." (7 votes)
- "Start design thinking with ecology first." (3 votes)
- "Attractive plants" (3 votes)
- "Beach access" (3 votes)
- "Kayak Access" (3 votes)
- "Remove chain link fence." (2 votes)
- "No parking except for handicapped." (2 votes)
- "Access for dogs to swim." (1 vote)
- "Seasonal foliage color." (1 vote)
- "Path viewing areas." (1 vote)
- "Provide Safe parking (people will park on street if they don't park on site)." (1 vote)

SUMMARY

- There is a tension between preservation of ecology and human use.
- The safety of Lafayette Street is a big concern for the community.
- There are contrasting ideas about parking on the street and creating new parking on the site.
- The community desires a simple, yet effective design.

EMILY BERG, JEFF DAWSON & ALLISON RUSCHP
THE CONWAY SCHOOL
GRADUATE PROGRAM IN SUSTAINABLE
LANDSCAPE PLANNING & DESIGN
WWW.CSLD.EDU
SPRING 2014

LEAD MILLS
CONSERVATION AREA DESIGN
MARBLEHEAD & SALEM, MA
485 LAFAYETTE STREET, SALEM, MA 01970

COMMUNITY INPUT

NEIGHBORING CONSERVATION AREAS

The Lead Mills property provides an important link between the Wyman Woods and Forest River Conservation Areas.

WYMAN WOODS

(East of Lead Mills Conservation Area)

- 30-acre wooded conservation area.
- Links Salem Harbor, Lead Mills, and Gatchell Park.
- Network of trails exploring a diverse terrain, ranging from woody swamps to steep rocky uplands.
- Home to The Hammond Nature Center, a former Girl Scout's day camp.

FOREST RIVER CONSERVATION AREA

(Southwest of Lead Mills Conservation Area)

- 30-acre estuarine area.
- Trails throughout the terrain range from steep exposed bedrock to tidal pools.
- Previously excavated for its sand and gravel.
- No trail signs.

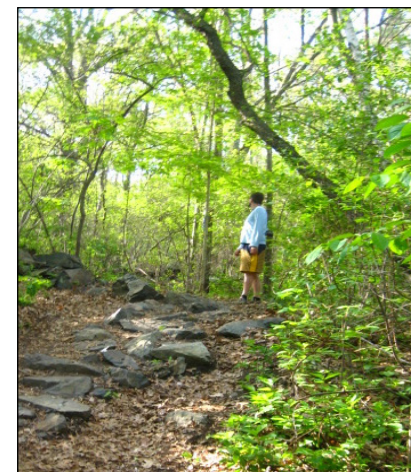

Trails leading into the forested Wyman Woods are steep and rocky.



Open trails along the Forest River conservation area take walkers along salt marsh habitat into forested areas.

IMPLICATIONS

- While there are many conservation lands in the area, most of them are forested. The Lead Mills Conservation Area has the opportunity to become the first meadow-like landscape in this mainly residential area.
- The site should have a seamless feeling in relationship to its neighboring conservation lands.

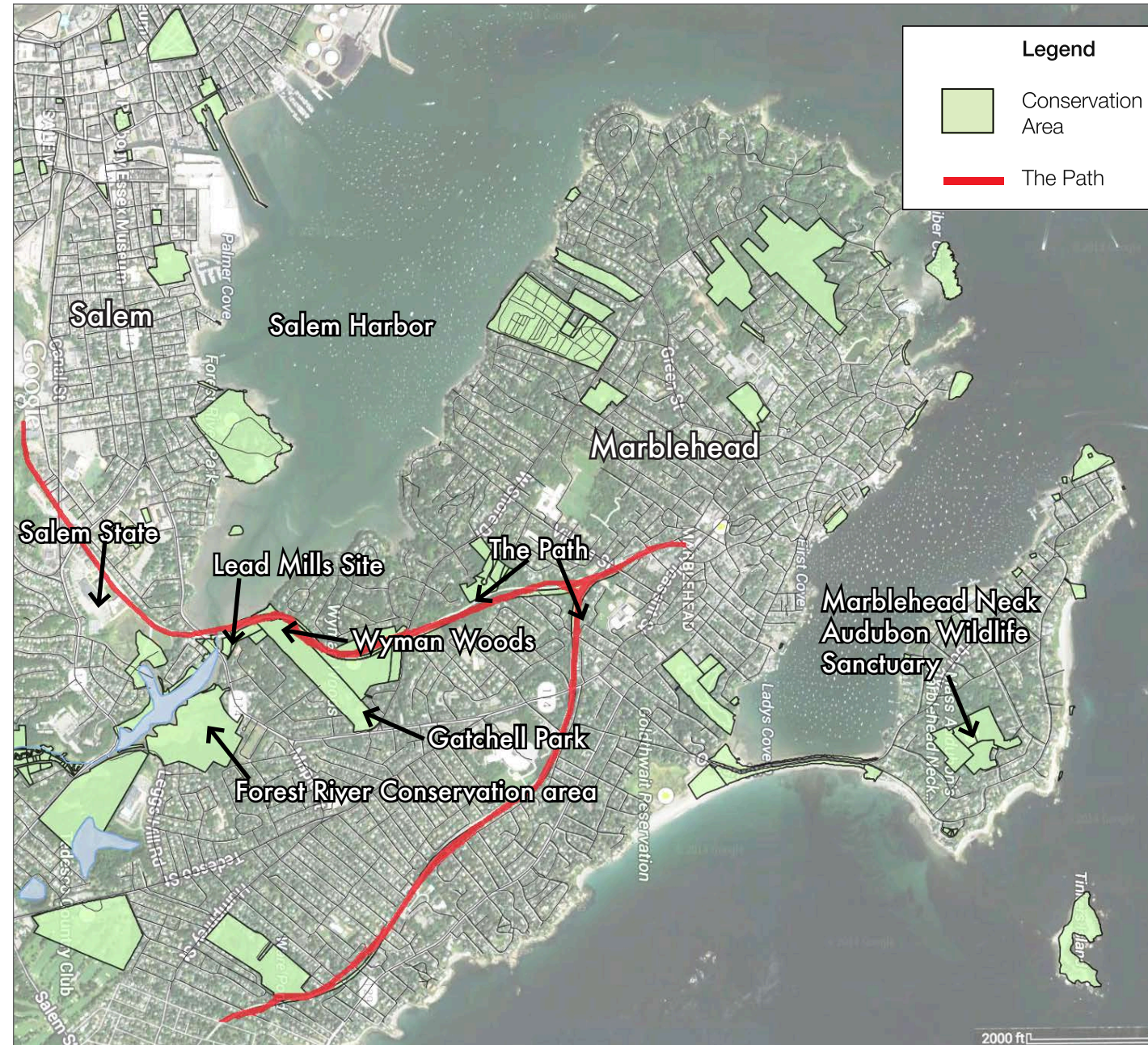

Salem and Marblehead have conservation areas that are connected by The Path, which also connects to both downtowns.

NOT FOR CONSTRUCTION. THIS DRAWING IS PART OF A STUDENT PROJECT AND IS NOT BASED ON A LEGAL SURVEY.

THE PATH

The Path is a frequently used recreation feature connecting town centers and conservation properties.

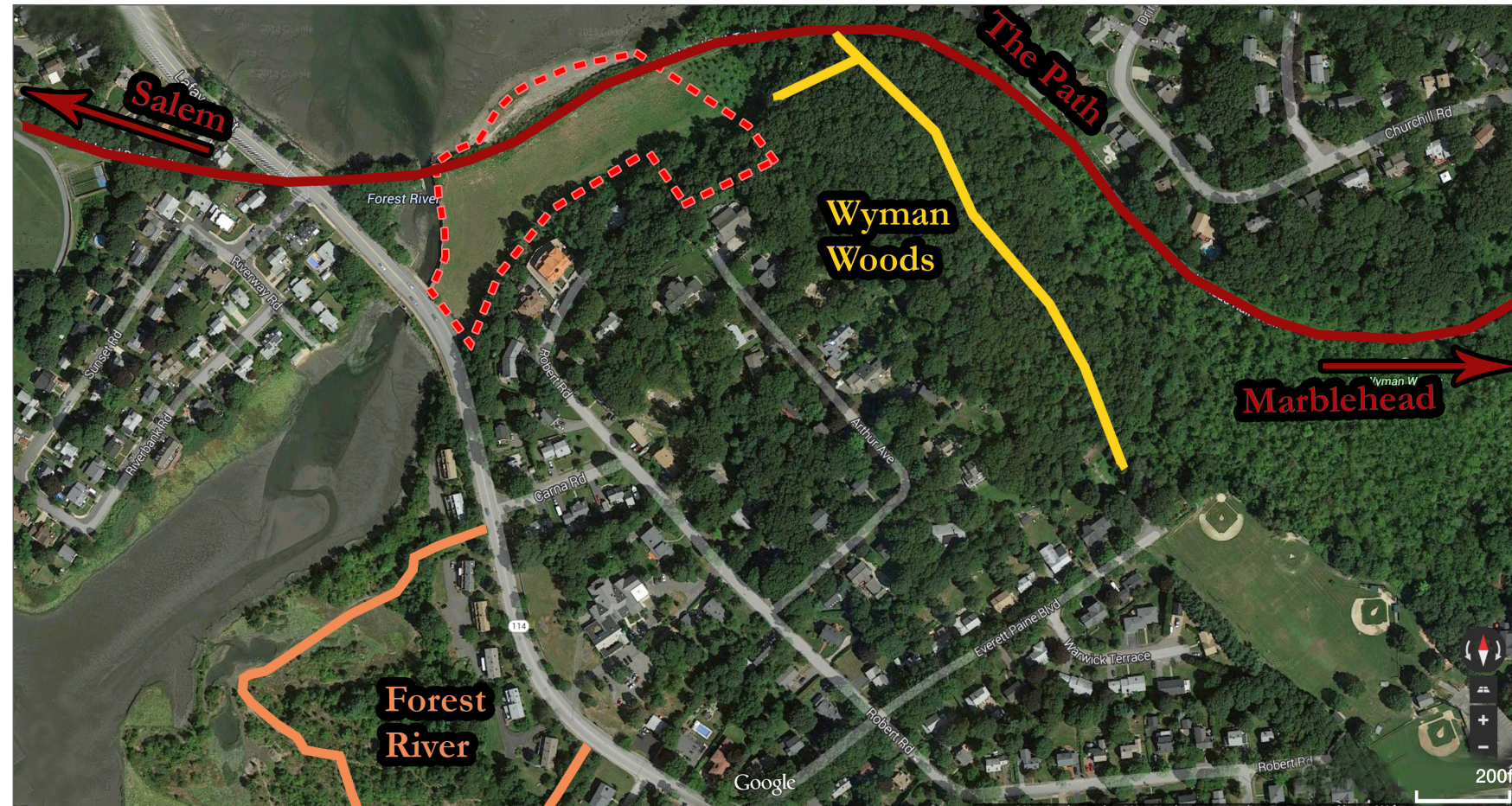

Highlighting the trails through conservation areas.

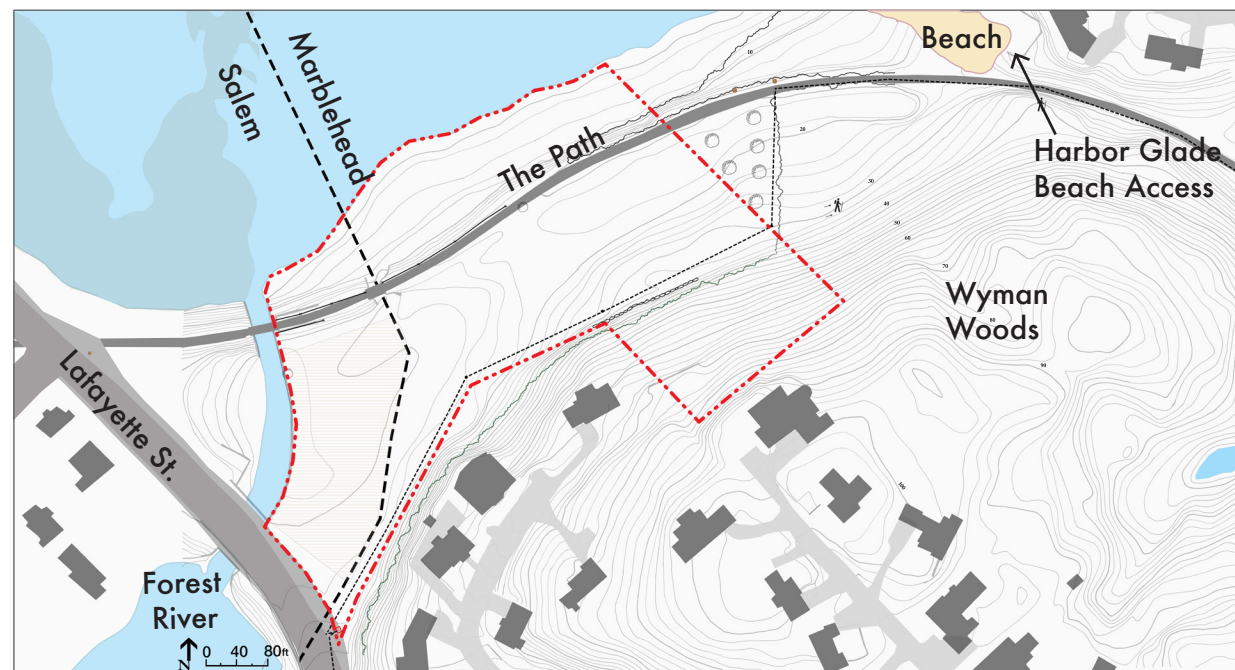

Beach access is just off the site at Harbor Glade.

OBSERVATIONS

The Path was built on the former Boston and Maine railroad bed, which is owned by the Town of Marblehead with jurisdiction split between the Water and Sewer Department and the Municipal Light Department. The railroad right-of-way, locally called "The Path," is 4.5 miles long. The Path is made of compacted gravel and stone dust. The Path connects to Wyman Woods in the east, Forest River Conservation Area to the west, Salem's paved bike path, and Salem State, 700 feet west of Lead Mills Park.

The Path at Lead Mills is heavily used by people strolling and exercising.

There is no clear, accessibly graded entrance to The Path at the Lead Mills property.

BEACH ACCESS

There is access to the shore from the Harbor Glade area, located only a few hundred feet from the Lead Mills property line. This open grassy area with a deciduous canopy leads to the rocky shore of Salem Harbor.

IMPLICATIONS

- The Path is currently not universally accessible due to bollards placed too closely together at its streetside entrances.
- The Path is a busy thoroughway for pedestrians and bicyclists who commute between the downtowns of Marblehead and Salem.
- Easements and right-of-ways create a complex hierarchy of authority.



The Path is used by walkers, runners and bikers.



Entrance to Harbor Glade. The access to the shore has gentle slopes.

NOT FOR CONSTRUCTION. THIS DRAWING IS PART OF A STUDENT PROJECT AND IS NOT BASED ON A LEGAL SURVEY.

EMILY BERG, JEFF DAWSON & ALLISON RUSCHP
THE CONWAY SCHOOL
GRADUATE PROGRAM IN SUSTAINABLE
LANDSCAPE PLANNING & DESIGN
WWW.CSLD.EDU
SPRING 2014

LEAD MILLS
CONSERVATION AREA DESIGN
MARBLEHEAD & SALEM, MA
485 LAFAYETTE STREET, SALEM, MA 01970

THE PATH

COASTAL BANK

The coastal bank is being revegetated after being heavily affected by remediation efforts. It is prone to erosion, invasive plant species, and human intrusion that affects vulnerable species habitat.

NOT FOR CONSTRUCTION. THIS DRAWING IS PART OF A STUDENT PROJECT AND IS NOT BASED ON A LEGAL SURVEY.

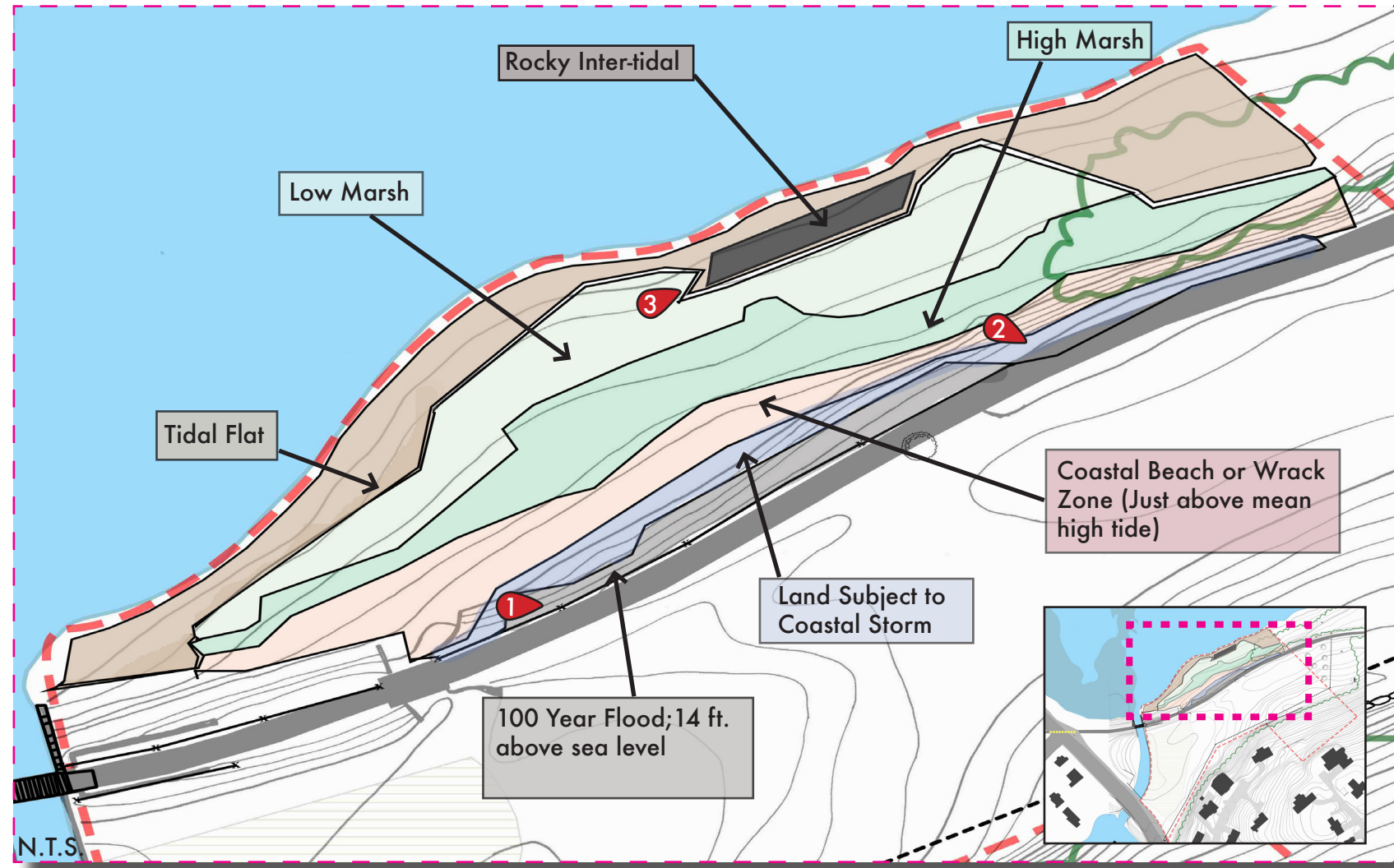

OBSERVATIONS

- Three years ago, Woodard & Curran rehabilitated and stabilized the coastal habitat with coconut fiber mats and vegetation plugs.
- Some areas have exposed mats and vegetation is not taking root.
- Invasive plants, such as bittersweet and multi-floral rose, dominate the shore embankment.
- For two more years, this area will be monitored by Woodard & Curran to ensure the bank is stabilized with vegetation.
- The tidal zone is considered a brackish marsh, which supports a number of species such as the threatened diamond-back terrapin and the horseshoe crab, which both nest in the marsh in early summer.
- This area is a key habitat for migratory shorebirds such as the heron and egret.

IMPLICATIONS

- The complex tidal zones are integral to the site and their diverse ecosystems should remain closed to people.
- Erosion and coastal habitat establishment are being addressed by the remediation company and are outside the scope of this project.
- An invasive plant management plan is needed to allow room for native plants to take root.
- Access along the slope and the beach should be limited to protect the sensitive habitat and its inhabitants.
- Erosion of the coastal bank weakens the resilience of the coastal habitat.
- The inhabitants of this vulnerable ecosystem are threatened by human activities, environmental degradation, and effects of climate change.



Fiber mats tucked into the embankment and planted to stabilize the slope.



Patches of fiber are exposed due to erosion and lack of vegetation.



Coconut fiber mats were used to establish marsh grasses.



Diamond-back turtles nest on the muddy marsh sands during summer months.



Horseshoe crabs nest in the tidal sands in early summer when humans are most likely to be using the area.

LEAD MILLS
CONSERVATION AREA DESIGN
MARBLEHEAD & SALEM, MA
485 LAFAYETTE STREET, SALEM, MA 01970

EMILY BERG, JEFF DAWSON & ALLISON RUSCHP
THE CONWAY SCHOOL
GRADUATE PROGRAM IN SUSTAINABLE
LANDSCAPE PLANNING & DESIGN
WWW.CSLD.EDU
SPRING 2014

UPLAND VEGETATION

Vegetation on the site is indicative of a disturbed area filled primarily with herbaceous, early succession species.

NOT FOR CONSTRUCTION. THIS DRAWING IS PART OF A STUDENT PROJECT AND IS NOT BASED ON A LEGAL SURVEY.

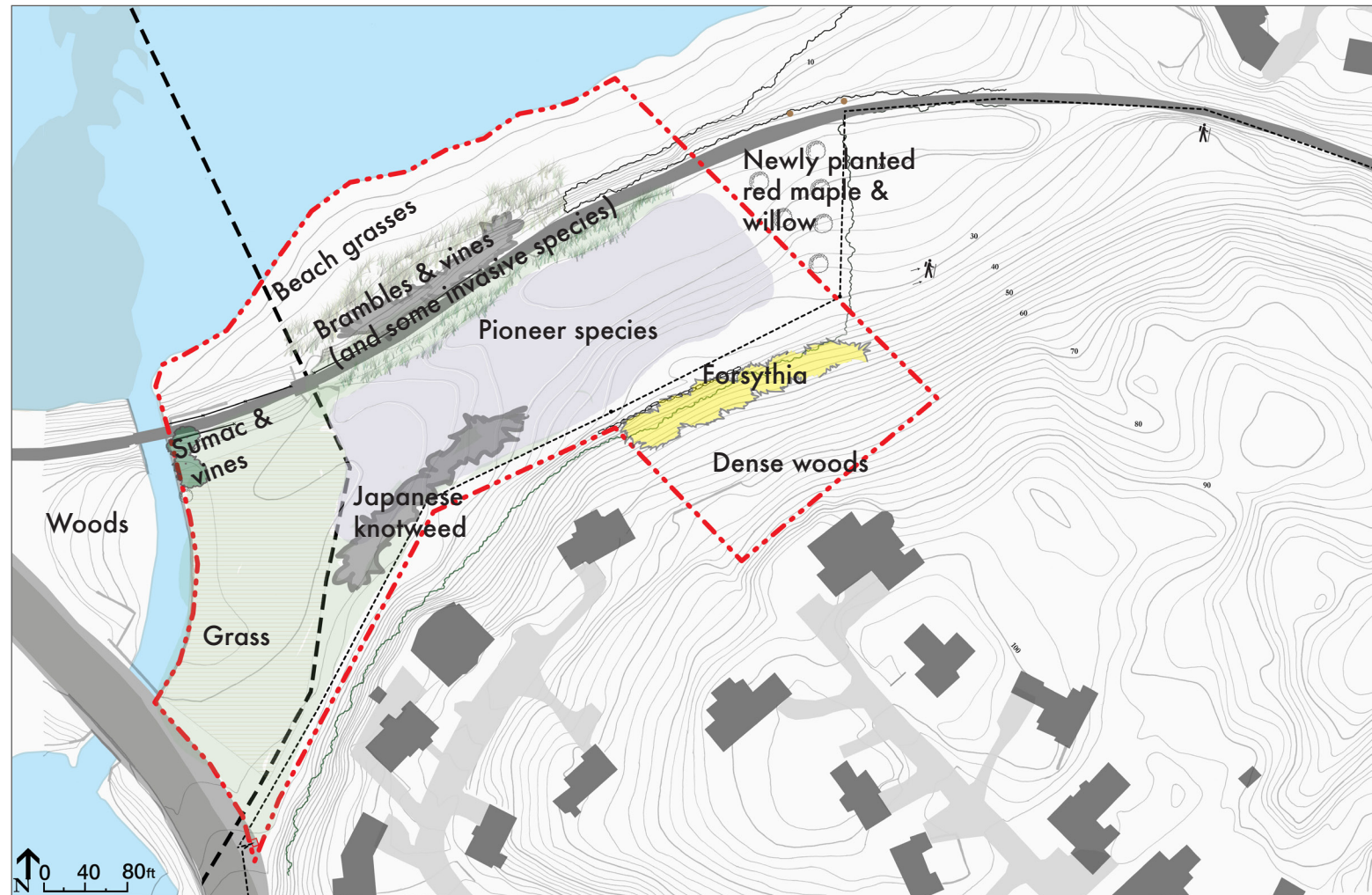

OBSERVATIONS

- Current vegetation at Lead Mills is characterized by sun-loving, early successional plants that appear first in disturbed areas.
- Brambles, invasive species, and grasses are pervasive, but not distributed evenly.
- The open landscape is mostly grass species and lacks a diversity of meadow species.

IMPLICATIONS

- Invasive management plan is likely necessary.
- Because invasive species are in mostly concentrated areas, they can likely be managed with hand-cutting methods (see page 27).
- There is an opportunity to add meadow species into the open space to establish a meadow habitat.
- Many of the large patches of pioneer species, such as mugwort, found at Lead Mills may be out-competed by other species once the habitat has fully stabilized post-remediation.



Sedges and grasses



Mullein



Juniper, brambles, grasses, bittersweet



Forsythia



Japanese knotweed



Maples and willows just off-site

LEAD MILLS
CONSERVATION AREA DESIGN
 MARBLEHEAD & SALEM, MA
 485 LAFAYETTE STREET, SALEM, MA 01970

EMILY BERG, JEFF DAWSON & ALLISON RUSCHP
 THE CONWAY SCHOOL
 GRADUATE PROGRAM IN SUSTAINABLE
 LANDSCAPE PLANNING & DESIGN
 WWW.CSLD.EDU
 SPRING 2014

UPLAND VEGETATION

ATLANTIC FLYWAY

Located on the Atlantic Ocean, the Lead Mills Conservation Area has the opportunity to support a variety of bird species as they migrate north and south, between their breeding seasons.



The coast of Northern Massachusetts is part of the Atlantic Flyway. (Map from U.S. Fish & Wildlife Service.)

There are thirty-two priority bird species within the Atlantic Flyway from Canada to South America. These are species that are targeted as needing extra conservation concern to ensure their continued survival. Many of these bird species frequent the coasts and wetlands of Northern Massachusetts.

Massachusetts Audubon has a wildlife sanctuary in Marblehead and is dedicated to land conservation that supports migratory shorebird habitats. The Lead Mills Conservation Area is an opportunity to build habitat that will support birds and especially priority bird species, such as the golden-winged warbler, and the red knot, among others.

Local ornithologist Jan Smith identified warblers as a species to focus on to the Lead Mills Conservation Area. Other birds known to stop over at Lead Mills Conservation Area include golden-winged warblers, grasshopper sparrows, red knots, and wood thrushes.



Golden-Winged Warbler
(*Vermivora chrysoptera*)



Grasshopper Sparrow
(*Ammodramus savannarum*)



Red Knot
(*Calidris canutus*)



Wood Thrush
(*Hylocichla mustelina*)

The National Audubon Society considers the Atlantic Flyway to include some of the most productive ecosystems (forests, beaches, and coastal wetlands) in the hemisphere. Over five hundred bird species, including birds that are considered priority species, travel the Atlantic Flyway between breeding seasons, and use the resources of coastal ecosystems in Northern Massachusetts for food and rest.

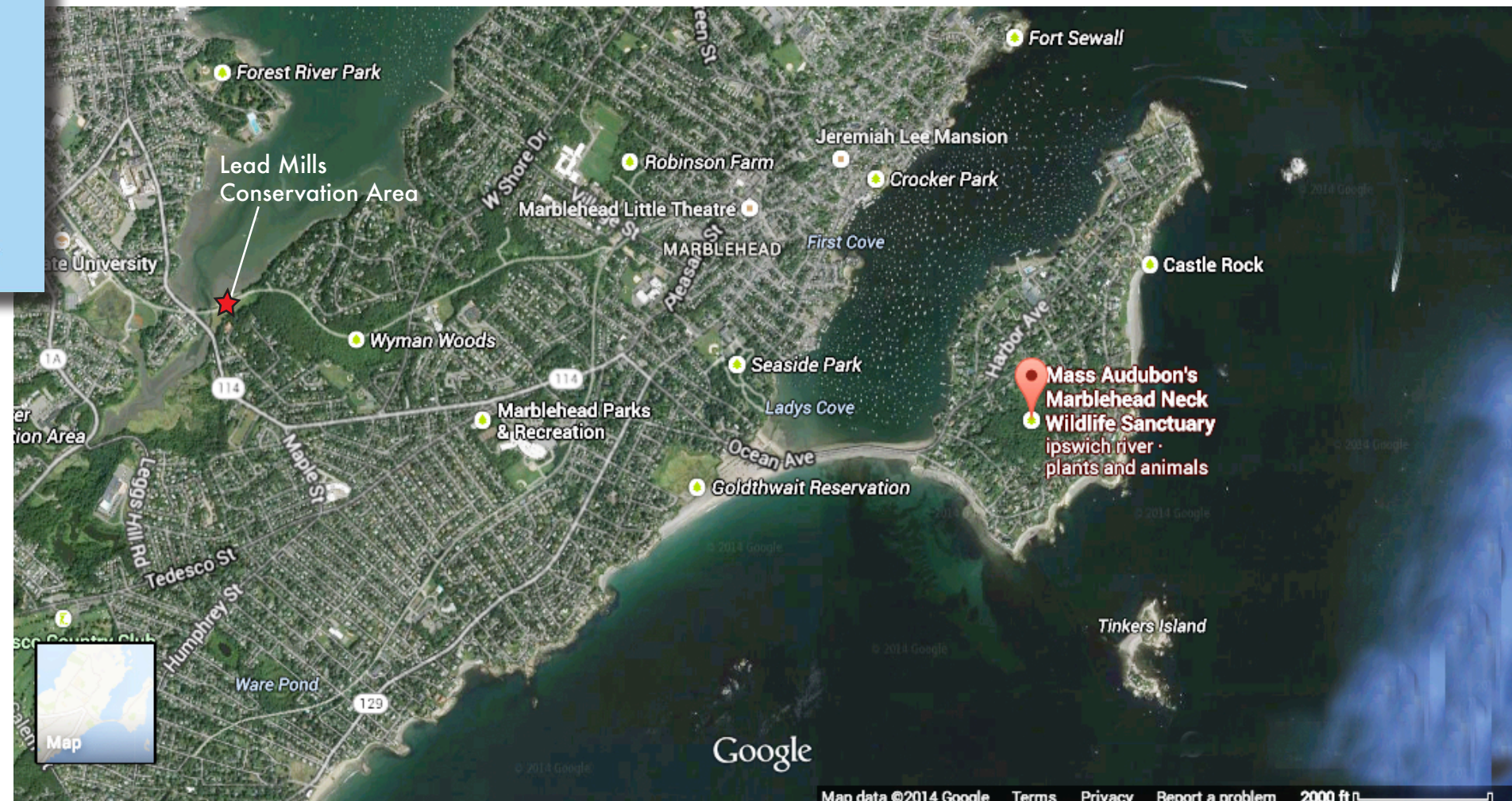

The Mass. Audubon Wildlife Sanctuary of Marblehead is located east of the Lead Mills Conservation Area. Both sites attract migrating birds traveling along the Atlantic Flyway.

NOT FOR CONSTRUCTION. THIS DRAWING IS PART OF A STUDENT PROJECT AND IS NOT BASED ON A LEGAL SURVEY.

LEAD MILLS
CONSERVATION AREA DESIGN
MARBLEHEAD & SALEM, MA
485 LAFAYETTE STREET, SALEM, MA 01970

EMILY BERG, JEFF DAWSON & ALLISON RUSCHP
THE CONWAY SCHOOL
GRADUATE PROGRAM IN SUSTAINABLE
LANDSCAPE PLANNING & DESIGN
WWW.CSLD.EDU
SPRING 2014

ATLANTIC FLYWAY

VIEWS

Expansive views of Salem Harbor can be seen from the high points on the site and from The Path where the chain-link fence is not present.



The site can be seen while crossing the “wet” bridge.



The mud flats of Salem Harbor at low tide can be seen from both bridges.



The fence serves as a trellis for plants such as poison ivy, and wild grape, and invasive plant species such as bittersweet.



Along The Path views are blocked by a chain link fence that also restricts access down the unstable beach embankment.



Where the fence is not present on The Path, views can be seen to the Harbor.



Expansive views of Salem Harbor can be seen from a high point in the southeast corner of the site.

OBSERVATIONS

- Most of the site can be seen from The Path and the bridges.
- Views of Salem Harbor can be seen from both bridges and on The Path where the fence is not present.
- Views are blocked by a 6-foot-high fence along The Path that restricts access down the unstable beach embankment.
- Long views are available through the site to the harbor.

IMPLICATIONS

- Slopes and fences detract or prohibit views from the low points on site and from places on The Path.
- The chain link fence could be changed to enhance views along The Path.

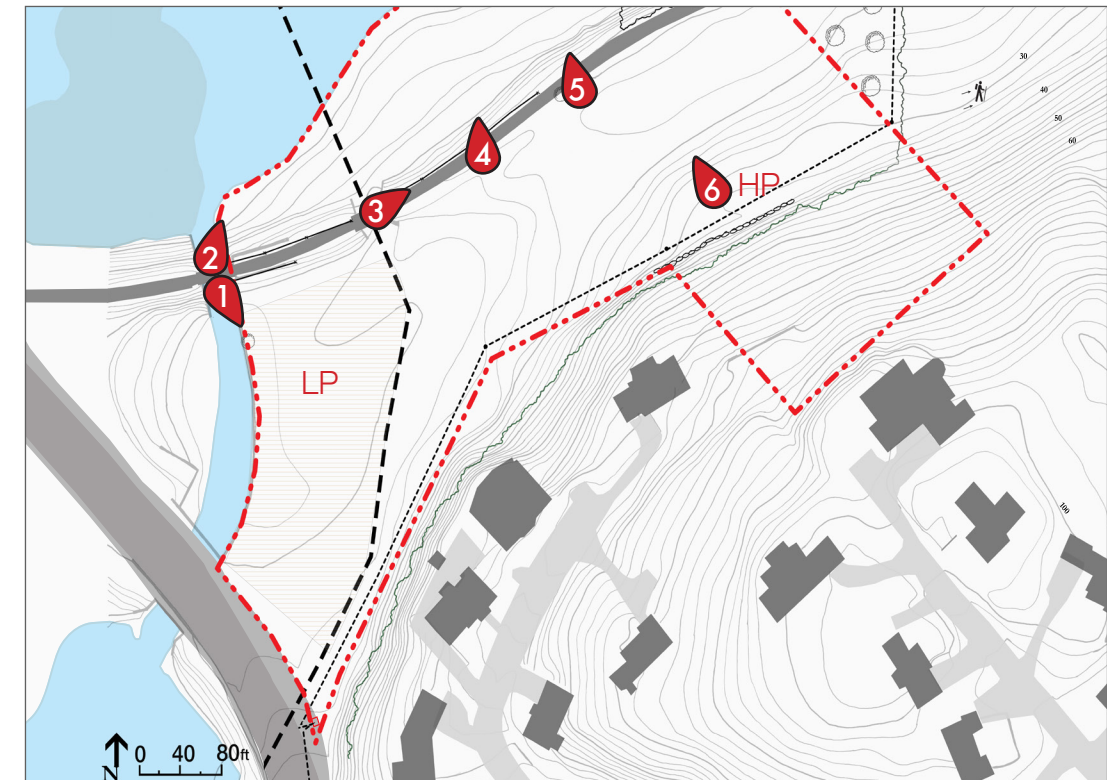

Locations from which the photos are taken and views can be seen.

NOT FOR CONSTRUCTION. THIS DRAWING IS PART OF A STUDENT PROJECT AND IS NOT BASED ON A LEGAL SURVEY.

LEGAL EASEMENTS & ENVIRONMENTAL BUFFERS

Legal easements preserve accessibility for utility maintenance and emergencies, and environmental buffers prevent development in sensitive areas. Any proposed infrastructure in the environmental buffers will need to be approved by the Massachusetts Department of Environmental Protection.

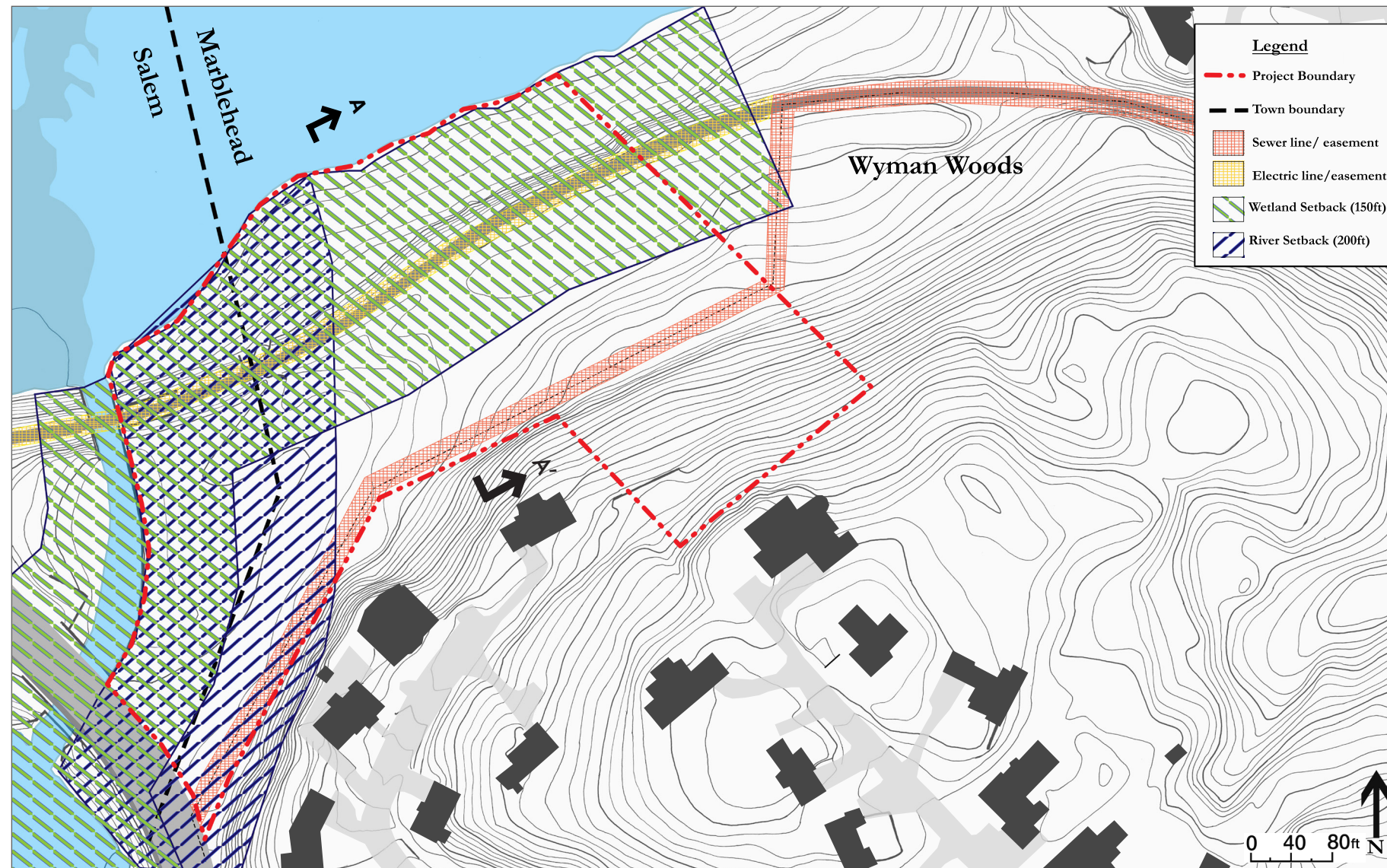

NOT FOR CONSTRUCTION. THIS DRAWING IS PART OF A STUDENT PROJECT AND IS NOT BASED ON A LEGAL SURVEY.

OBSERVATIONS

- A wetland buffer of 150 feet helps to keep waterbodies clean and reduce the impact that pollution has on species dependent on the wetland and its water.
- A river buffer of 200 feet along the Forest River helps prevent flooding from storms and provides an important edge for plants and wildlife next to the river.
- Buffers prohibit development without approval.
- An electric line under The Path is maintained by the electric utility company. There is a twenty-foot-wide easement over The Path requiring approval from the electric company for any intended vegetation in this space. The electric company also controls the dry bridge gate that can provide access the shore.
- A sewer line runs along the southern property boundary in a twenty-foot-wide easement. Vehicles need to access the line, precluding woody vegetation from being planted on this area.

IMPLICATIONS

- The Massachusetts Department of Environmental Protection will need to approve any infrastructure proposed in the environmental buffers.
- Any proposed changes within easements will need to be approved by the electric and sewer companies.
- The site's existing open landscape provides an area for flooding during storms.

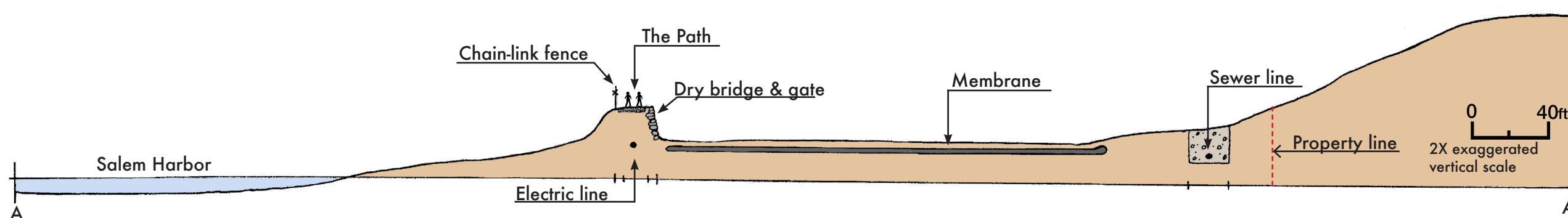

Marblehead's main electrical line runs under The Path and a sewer line runs along the southern property boundary.

EMILY BERG, JEFF DAWSON & ALLISON RUSCHP
THE CONWAY SCHOOL
GRADUATE PROGRAM IN SUSTAINABLE
LANDSCAPE PLANNING & DESIGN
WWW.CSLD.EDU
SPRING 2014

LEAD MILLS
CONSERVATION AREA DESIGN
MARBLEHEAD & SALEM, MA
485 LAFAYETTE STREET, SALEM, MA 01970

RESTRICTIONS

LAFAYETTE STREET (ROUTE 114)

It is important that safety be improved for pedestrians and bicyclists along Lafayette Street and to establish clearly marked areas for vehicles.

NOT FOR CONSTRUCTION. THIS DRAWING IS PART OF A STUDENT PROJECT AND IS NOT BASED ON A LEGAL SURVEY.



The small parking bump-out is restricted by an underground sewer room and fire hydrant that need to remain accessible.



Entrance to the Lead Mills Conservation Area is blocked by vegetation for those driving north on Lafayette Street.



The entrance to the site from Salem is not obvious. Worn paths can be seen along the left side of the road but a sidewalk would better serve visitors.

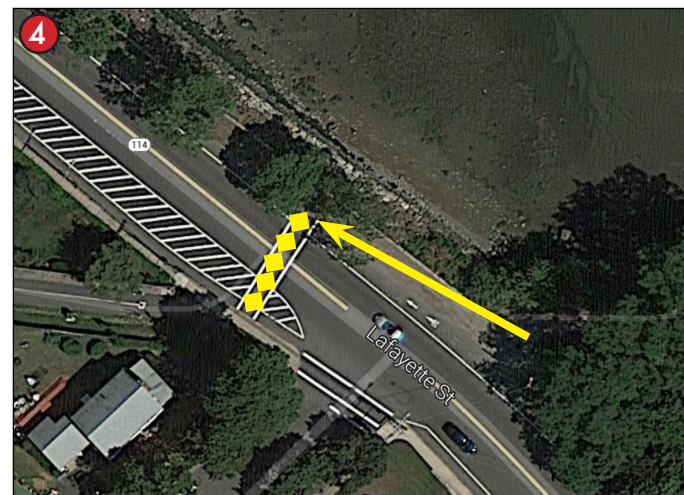

A recent addition of painted lines on the road may calm traffic at this intersection but the crosswalk is off-set from The Path which can be confusing for pedestrians.



A roadside shoulder near the entrance to The Path has room for one vehicle.



Where The Path meets Lafayette Street the crosswalk is offset from both entrances.

OBSERVATIONS

- Lafayette Street, the main road leading visitors to the Lead Mills Conservation Area, is a commuter route and state highway connecting between Salem and Marblehead.
- For those driving from Marblehead, the entrance to the Lead Mills Conservation Area is hidden by vegetation and the curve in the road.
- Parking is along the street in a bump-out that fits 4 to 5 cars. There is another bump-out near The Path entrance that has the potential to be an additional parking space.
- The entrance for those coming from Salem is not clear and one must cross traffic to park along the road.
- There is one crosswalk for The Path that is offset from the entrance at the Lead Mills Conservation Area.
- There is no sidewalk connecting the entrance to The Path to the main Lead Mills Conservation Area entrance.
- A traffic impact and access study completed by MDM Traffic Consultants Inc., in May of 2005 identified four problems on Lafayette Street: excessive travel speeds, lengthy road crossings for pedestrians and bicyclists, lack of turn-around areas, and a lack of continuous sidewalk along the northern side.

IMPLICATIONS

- The entrance to Lead Mills Conservation Area should be more visible, with signs, clear turning areas, and reduction of vegetation.
- Pedestrian and bicyclist safety could be improved by slowing traffic, adding crosswalks, and connecting missing sidewalks.

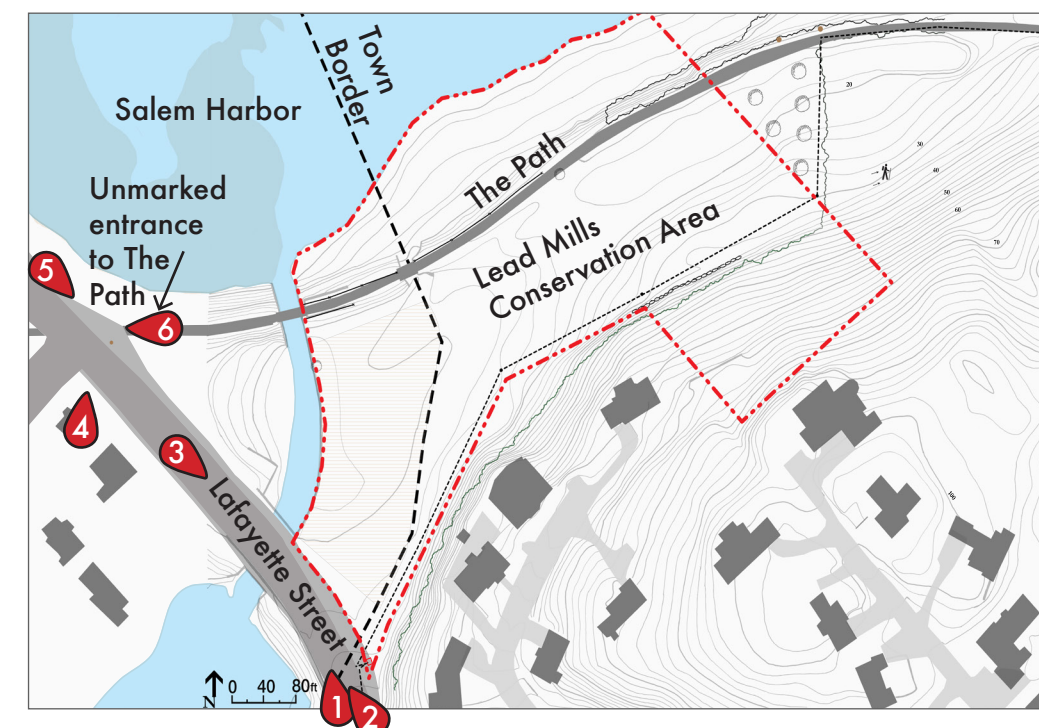

HYDROLOGY & ACCESS

The topography of the site dictates where paths can be made, and directs the flow of water entering the site.

NOT FOR CONSTRUCTION. THIS DRAWING IS PART OF A STUDENT PROJECT AND IS NOT BASED ON A LEGAL SURVEY.

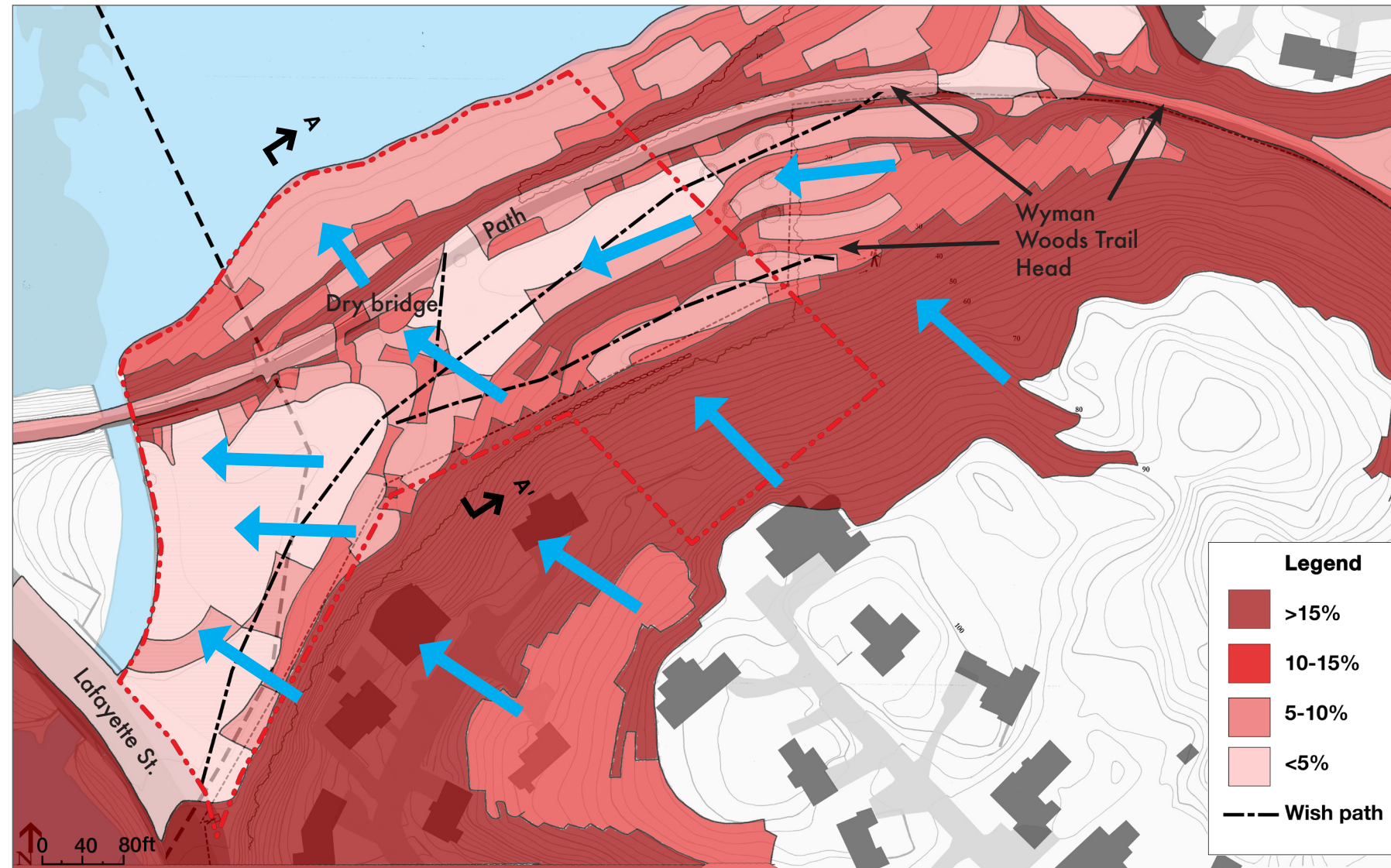

OBSERVATIONS

- Terrain on the site is rolling. The grade is even with Lafayette Street and gently rolls down across the site west to east.
- From north to south, the site starts below sea level and rises up to 70 feet.
- The Path's embankment is ten feet above grade, creating a steep wall.
- Stormwater run-off enters the site from the steep slopes to the south.
- The flow of water is impeded by The Path embankment. The water is directed under the dry bridge into the harbor and over the river wall into the Forest River.
- Paths are visible in the grass on the site leading to The Path and Wyman Woods.

IMPLICATIONS

- Because the middle of the site is fairly flat, minimal earth moving will be needed to make the site universally accessible.
- The steeper slopes of The Path's embankment and the southeast corner of the site may need to be regraded in order to make them universally accessible.
- The worn paths indicate the site's current level of use and the need for formal paths to prevent erosion and provide clear connections to neighboring trails.



Well-worn wish path on the site connect visitors from Lafayette Street to The Path and Wyman Woods.

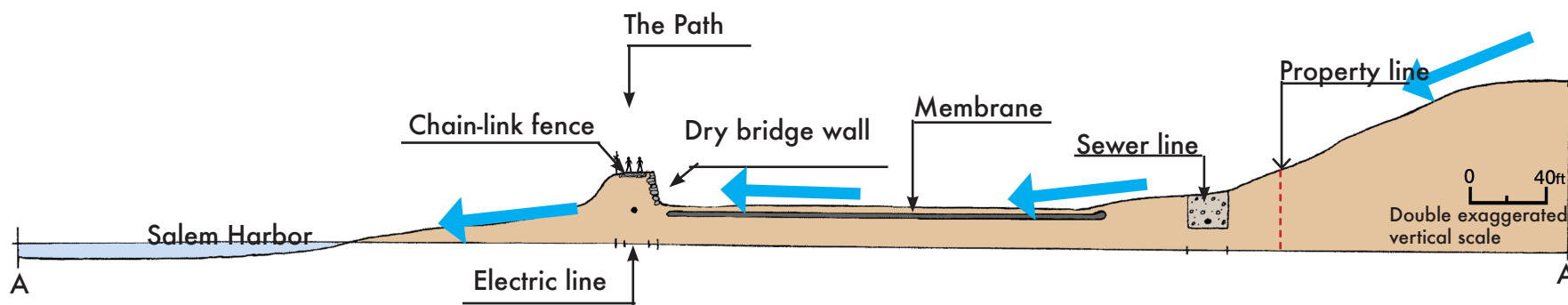

Stormwater runoff enters the site from the steep slopes to the south. The flow is blocked by the embankment of The Path and the runoff is directed under the dry bridge into the Salem Harbor and over the river wall.

EMILY BERG, JEFF DAWSON & ALLISON RUSCHP
 THE CONWAY SCHOOL
 GRADUATE PROGRAM IN SUSTAINABLE
 LANDSCAPE PLANNING & DESIGN
 WWW.CSLD.EDU
 SPRING 2014

LEAD MILLS
CONSERVATION AREA DESIGN
 MARBLEHEAD & SALEM, MA
 485 LAFAYETTE STREET, SALEM, MA 01970

TOPOGRAPHY

REMEDIATION

The former lead mills still have an impact on the site today, as evidenced by contaminated soils and restricted uses.

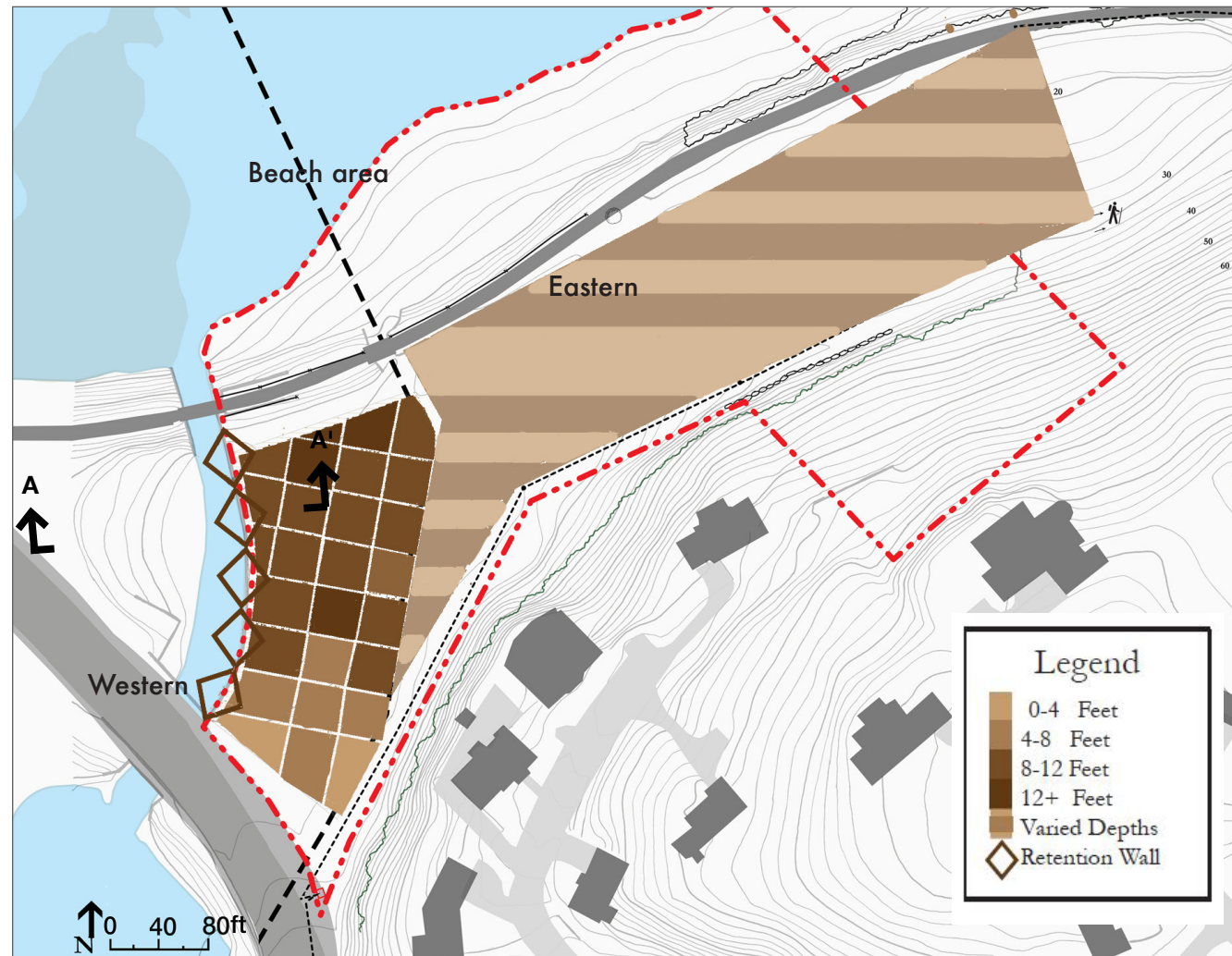

OBSERVATIONS

- Lead-impacted soil was remediated using a variety of methods, corresponding to levels of lead concentrations.
- Activities and Use Limitations (AUL) exist on the Salem portion of the site.

IMPLICATIONS

- Because the AUL bans use of the property for single-family residences, schools, and playgrounds, the town has elected to limit park use to passive recreation only.
- Because the AUL prohibits the use of on-site soils for human food production, signs warning against harvesting any edibles on site will be needed.
- Restrictions at Lead Mills ban any activity that may damage the constructed barrier or involve removal or disturbance of (stabilized) lead impacted-soils. These restrictions need to be reflected in any landscape design.
- Lead-impacted soils in the eastern upland of the site were chemically stabilized, reducing solubility, mobility, and bioavailability of lead in the environment. There is no restriction on planting new vegetation in this area.

*Note: A licensed Site Professional LSP, must approve proposed activities over the AUL area. The LSP for the Lead Mills Conservation Area is John Thompson, at Woodard & Curran Inc.

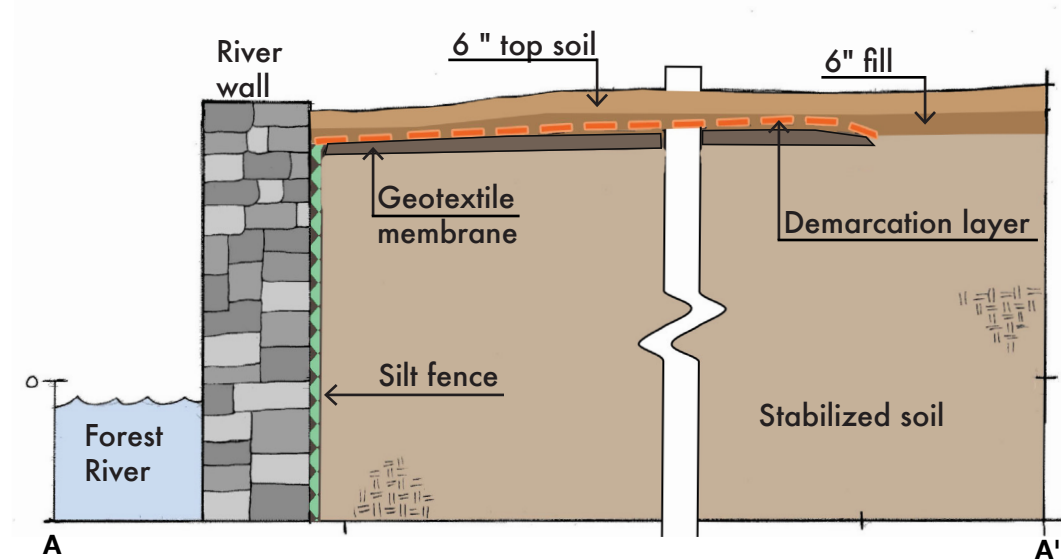

The stabilized and remediated soil in the western area is held down by a non-woven geotextile fabric, an orange demarcation layer, six inches of clean fill, and six inches of topsoil. There is also a silt fence along the Forest River seawall to help stabilize the soil.

Above:
The western area, where the former lead mill once sat, was most heavily contaminated with lead. This area was excavated to varying depths based on the different concentrations of lead contamination. Different remediation methods were used throughout the site to stabilize the soil to permitted levels.



Project site post-remediation and before seeding in 2012.

NOT FOR CONSTRUCTION. THIS DRAWING IS PART OF A STUDENT PROJECT AND IS NOT BASED ON A LEGAL SURVEY.

RISING TIDES

Rising tides and more severe weather will affect the site by inundating The Path's embankment and potentially flooding the site's existing open landscape.

NOT FOR CONSTRUCTION. THIS DRAWING IS PART OF A STUDENT PROJECT AND IS NOT BASED ON A LEGAL SURVEY.

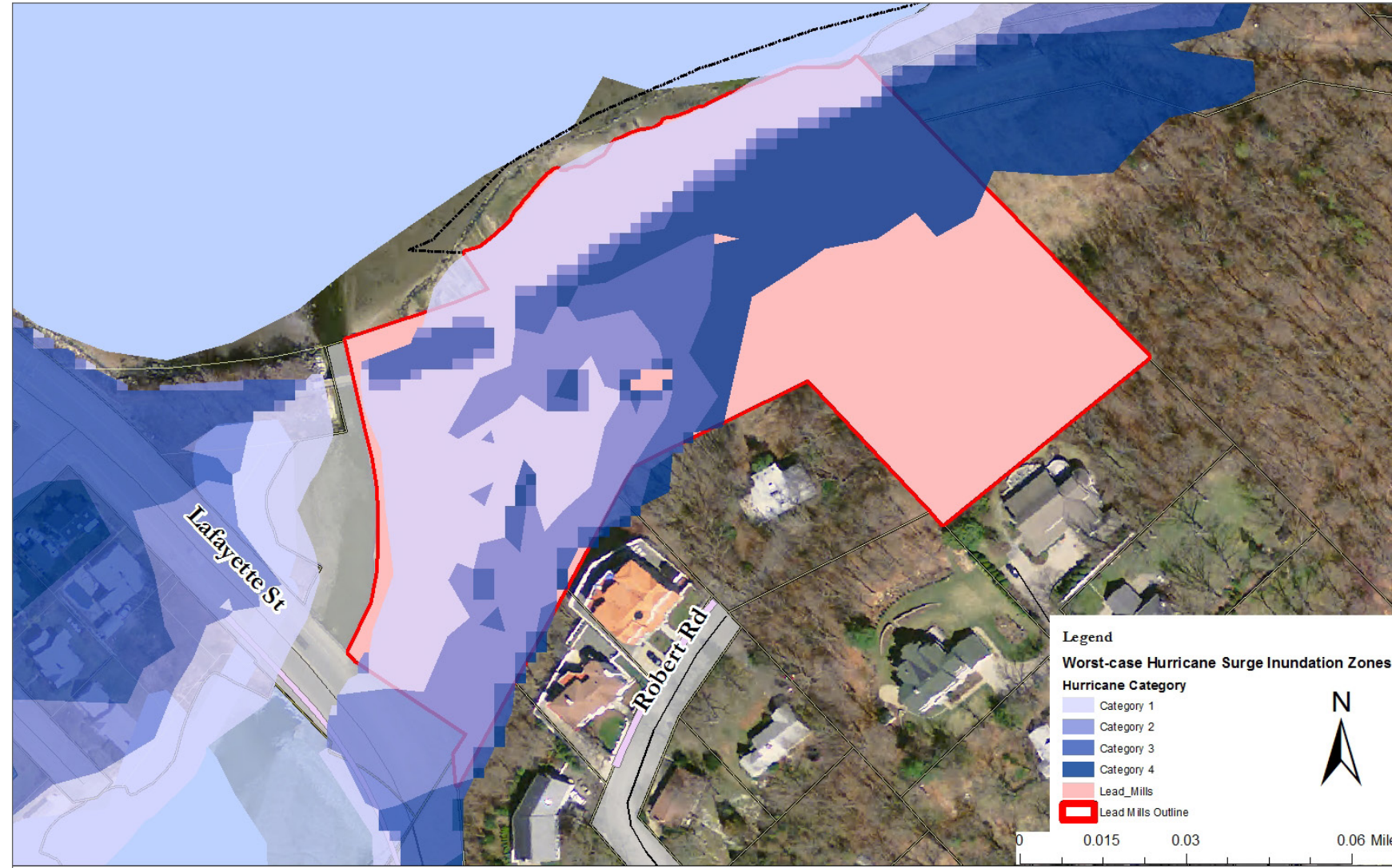

The property is predicted to be flooded in even a Category 1 hurricane.

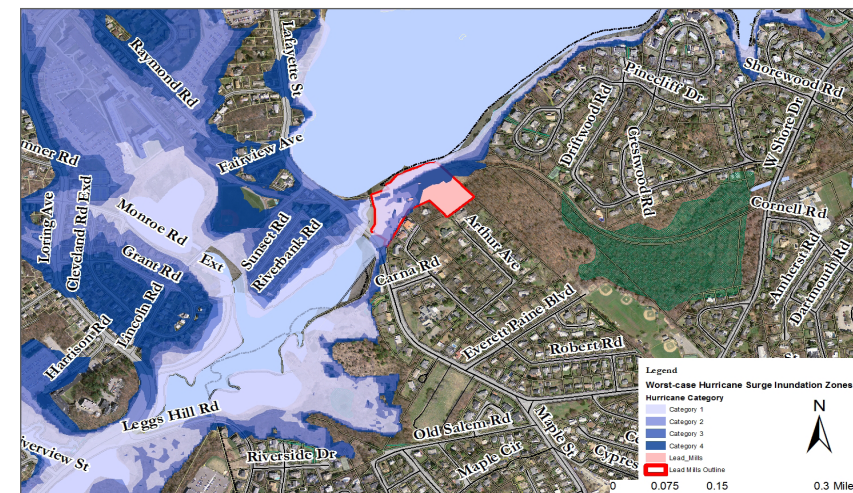

Salem already has residential areas that experience severe flooding.



Tide entering the Forest River from Salem Harbor. At high tide the water is only a few feet below the top of the wall. During a large storm this wall could potentially be breached.

OBSERVATIONS

- At high tide the harbor's water already gets within a few feet to the top of the retention wall.
- The Forest River Conservation Area helps mitigate stormwater through its network of inland waterbodies and open landscape, which exits through the river adjacent to the Lead Mills Conservation Area.
- GIS data shows that the site is impacted by flooding in even a Category 1 hurricane.

IMPLICATIONS

- Minimizing on-site infrastructure that could be damaged by flooding and preparing the site for potential floods should be a priority for the Lead Mills Conservation Area.
- The site's open landscape provides an area that can be flooded without impacting residential areas.
- Over time, with increased flooding, it may be important to have more salt-tolerant vegetation in the conservation area.

TIDAL EVENTS

A recent article "Is Salem Ready for a Superstorm" (Salemnews.com) provides some insight into how larger storms could impact the area.

Neighbors of the Lead Mills Conservation Area are aware of the ocean's potential danger. "In 1996, it flooded so badly," said one, "that residents of Jefferson Avenue took to boats and literally swam from house to house. Even on sunny days, the water sometimes rises on Canal Street at high tide."

Stephen Young, a Geography Professor at Salem State, recently completed a study with his students that shows how a storm like Hurricane Sandy would impact Salem's critical resources. The DPW, Police and Fire Department Headquarters would all be flooded.

Salem's energy and sustainability manager, Jeff Elie, warned, "The threat is real, climate change is happening. It's not a debate."

SUMMARY ANALYSIS

The site's utility infrastructure, easements, buffers, and topography will strongly direct what uses, access, and vegetation are appropriate.

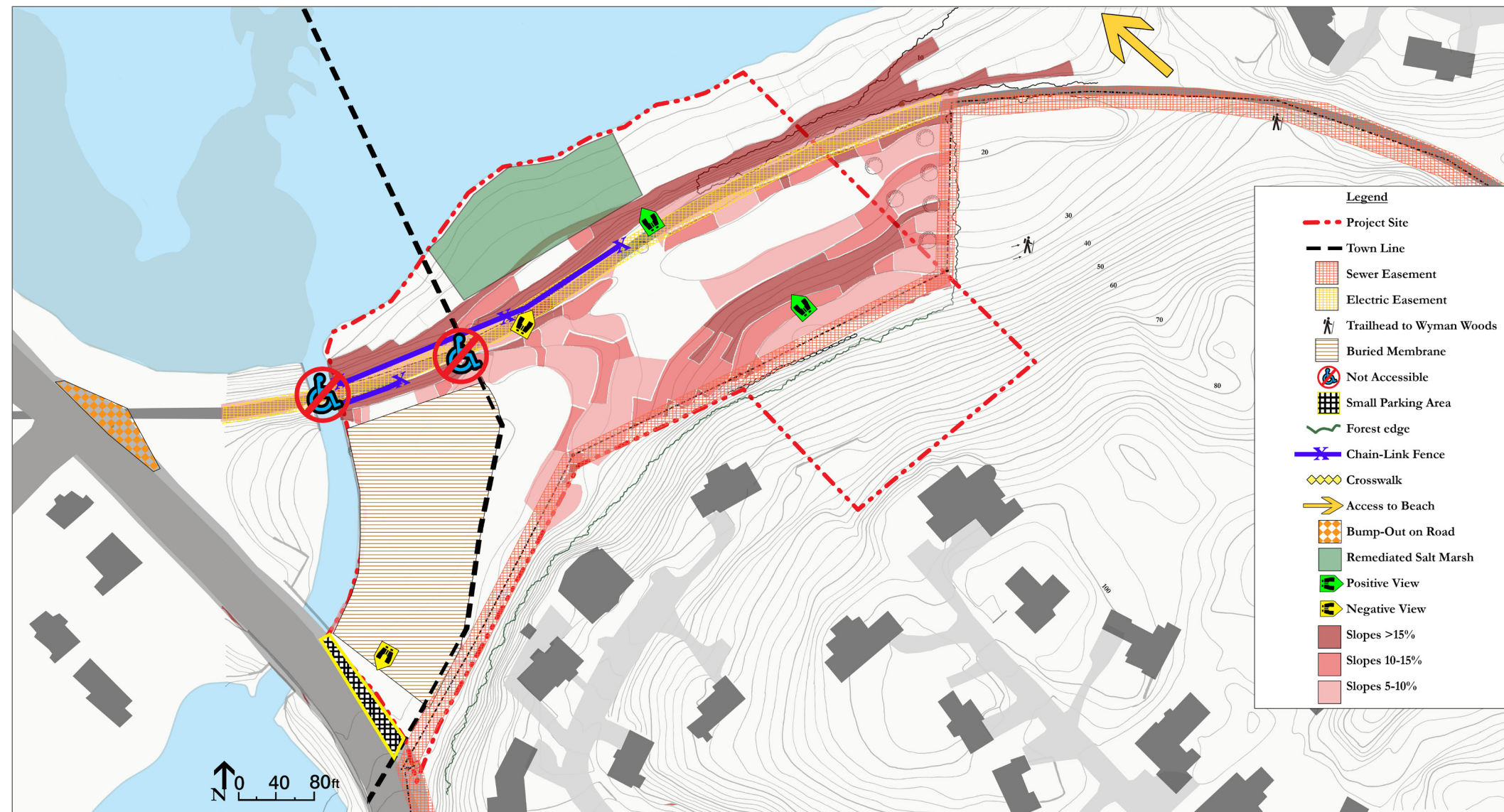

NOT FOR CONSTRUCTION. THIS DRAWING IS PART OF A STUDENT PROJECT AND IS NOT BASED ON A LEGAL SURVEY.

- Utility easements (sewer and electric) must remain accessible for maintenance and emergencies.
- A non-woven membrane one foot below the surface restricts the uses on the western end of the property. This area can be used for passive recreation, but any kind of planting or activity that will disturb the soil is banned.
- Steep slopes restrict universal access to The Path and to the high ground in the southeast corner of the site.
- Bollards on the bridges are set too close to allow wheelchair access on The Path through Lead Mills Conservation Area.
- The small pull-out on Lafayette Street provides minimal space for parking and is potentially dangerous due to high traffic flow.
- The bump-out near The Path entrance could potentially be used for limited parking as it meets necessary grade, size, and visibility requirements.
- Positive views from high points and into the site should be highlighted in the design.
- Negative views looking at parking and a chain-link fence need to be improved for an enhanced visitors experience.
- Fencing along The Path is necessary to prevent further erosion of the beach embankment but it is overgrown with vegetation and blocks views of Salem Harbor. This fencing could be changed to better serve the visitors to Lead Mills Conservation Area.
- There is beach access a few hundred feet to the east of the site as an alternative to beach access from Lead Mills Conservation Area. This could be highlighted by informational signs on site.
- Once established the revegetated salt marsh can provide important beach habitat for wildlife and act as a buffer against storm surges. Therefore it may be best to preserve this northern area of the Lead Mills Conservation Area from human use/disturbance.

ALTERNATIVE #1: UNIVERSALLY ACCESSIBLE DESIGN

Graded trails and on-site parking allow for universal access of the conservation area and The Path. A lookout at the high point has views of the harbor.

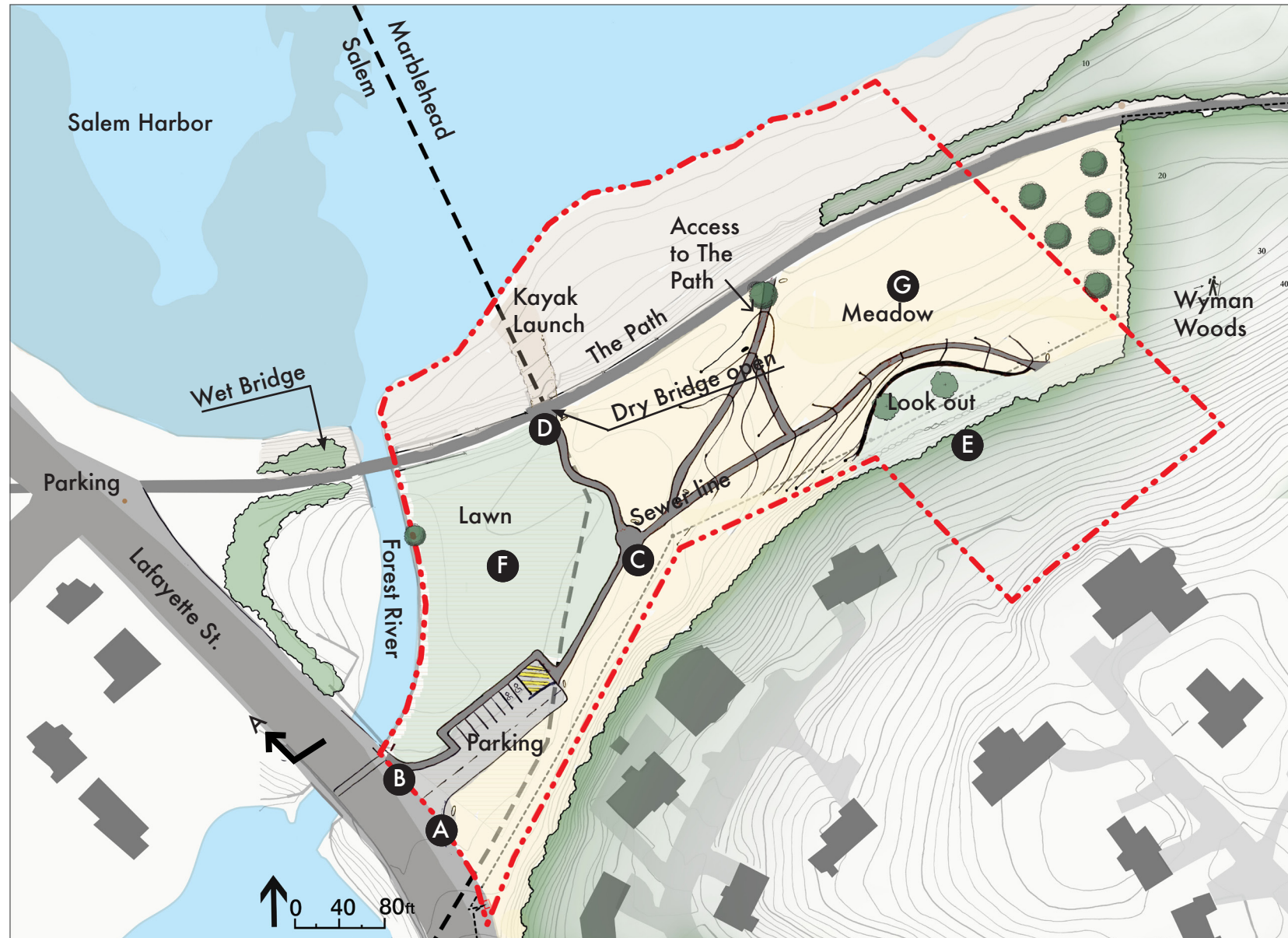

NOT FOR CONSTRUCTION. THIS DRAWING IS PART OF A STUDENT PROJECT AND IS NOT BASED ON A LEGAL SURVEY.

PROS

- Safe parking, not exposed to street traffic
- All trails are universally accessible
- Viewing points to the water are emphasized
- Added vegetation provides food for migratory birds
- Access to the beach for non-motorized boats

CONS

- Requires earth moving, high impact to the site through regrading for trails and parking
- Retaining wall and parking lot materials may be expensive
- Parking lot will increase runoff into Forest River and Salem Harbor
- Open dry bridge impacts fragile coastline habitat

Parking is created on the southeast end of the site, off Lafayette Street, to accommodate eight cars with two universally accessible spaces **A**. Sidewalks connect the street around the parking lot, and meet the trail into the park at grade level for easy access **B**.

Compacted gravel trails are graded at a 5% slope to allow wheelchair access through the site **C**. These trails take visitors either along mowed turf and beneath the dry-bridge underpass to a kayak launch, or up to The Path **D**.

Visitors can follow a curving trail east, around a tapered stone retaining wall to a flat lookout **E**. Two trees shade this lookout on hot summer days with expansive views to Salem Harbor and the meadow below. Aside from the mowed turf area **F**, the site is largely wild meadow **G** to provide habitat for birds, insects and other wildlife, and to maintain the open character of the site.

EMILY BERG, JEFF DAWSON & ALLISON RUSCHP
THE CONWAY SCHOOL
GRADUATE PROGRAM IN SUSTAINABLE
LANDSCAPE PLANNING & DESIGN
WWW.CSLD.EDU
SPRING 2014

LEAD MILLS
CONSERVATION AREA DESIGN
MARBLEHEAD & SALEM, MA
485 LAFAYETTE STREET, SALEM, MA 01970

ALTERNATIVE #1

ALTERNATIVE #2: THE MISSING LINK

Signs share the story of the site as people move through the Conservation Area, and added vegetation supports wildlife.

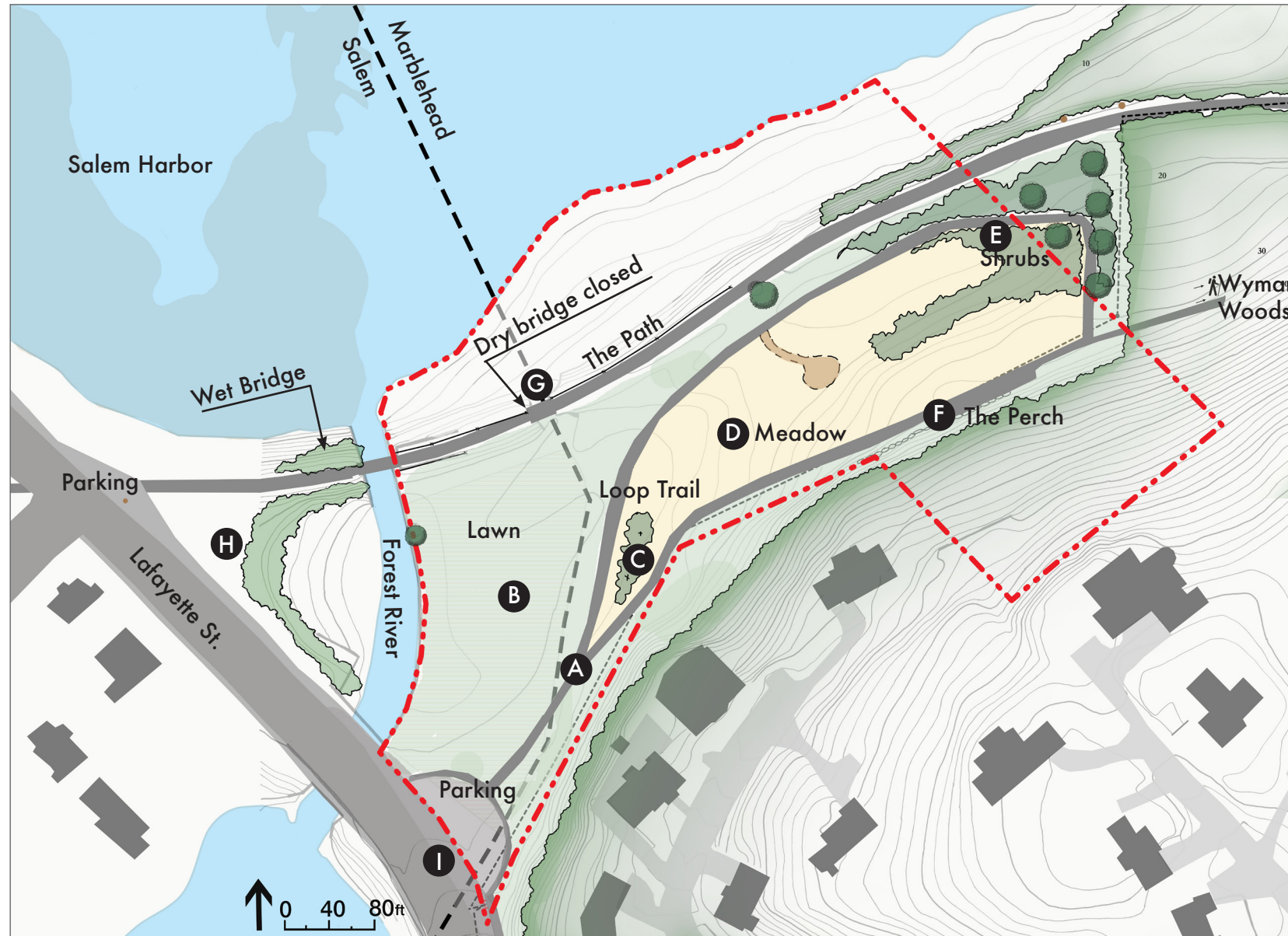

NOT FOR CONSTRUCTION. THIS DRAWING IS PART OF A STUDENT PROJECT AND IS NOT BASED ON A LEGAL SURVEY.

PROS

- Improved wildlife habitat
- Emphasis on conveying historical and ecological information
- Loop trail with connections to Wyman Woods.
- New bump-out on the trail universally accessible
- Nook-like areas for visitors to enjoy

CONS

- Parking improvements will be costly
- Not universally accessible
- Maintenance will require education and training
- Potential for misbehavior in less visible hang out areas
- Fill needed to create view area on trail may be costly

Into Lead Mills Conservation Area from Lafayette Street, the eye views layers of vegetation starting low in the west and getting taller to the east. A loop trail on the property highlights areas that are historically and ecologically important for the site and its visitors **A**, and allows visitors to casually stroll through the site.

An open lawn invites visitors to picnic **B**, and a stand of paper birches buffer activity from Lafayette Street **C**. The center of the site is a meadow providing important habitat for birds **D**, who can also rest in nearby planted shrubs that surround the trail and merge into Wyman Woods **E**.

The high point of the property, The Perch, is accentuated with granite blocks that provide seating **F**. The views across Salem Harbor can be easily enjoyed here, as can remnants of stonewalls on the periphery of the forest.

The fences along the trail are changed, reducing the height, and removing the chainlink, replacing it with a low wooden fence **G**. The triangular area of land between Lafayette Street and Forest River, which is owned by Salem is incorporated into the design to help keep this area clean and prevent further littering **H**. Parking for six cars along Lafayette Street where the existing parking takes place is turned into a half rotary **I**.

LEAD MILLS
CONSERVATION AREA DESIGN
MARBLEHEAD & SALEM, MA
485 LAFAYETTE STREET, SALEM, MA 01970

EMILY BERG, JEFF DAWSON & ALLISON RUSCHP
THE CONWAY SCHOOL
GRADUATE PROGRAM IN SUSTAINABLE
LANDSCAPE PLANNING & DESIGN
WWW.CSLD.EDU
SPRING 2014

ALTERNATIVE #2

ALTERNATIVE #3: WILDLIFE SANCTUARY & TRAILHEAD

Connecting visitors to surrounding trails while creating an undisturbed space for migratory birds to rest and feed.



NOT FOR CONSTRUCTION. THIS DRAWING IS PART OF A STUDENT PROJECT AND IS NOT BASED ON A LEGAL SURVEY.

PROS

- Low-mow lawn and meadow reduce site's need for regular maintenance
- Habitat protected along the shore
- No need for additional parking areas
- Trails to The Path are made universally accessible
- Trail signs lead visitors through the site to connecting trails
- Views are improved into the site from Lafayette Street

CONS

- Maintenance crews will require training for specific shrub and wildlife regimes
- Parking is along the flow of traffic, and turning left out of the parking area towards Marblehead could be difficult
- Trails on the site are not universally accessible

This simple design increases wildlife habitat while connecting visitors through the conservation area to surrounding areas. Mowed trails take visitors through the Lead Mills Conservation Area to the Wyman Woods trailhead and The Path **A**. An open lawn area allows visitors to picnic **B**. A tall meadow limits access across the northeast side of the property, leaving it for nesting and visiting birds **C**. New shrubs in the southeast corner of the property create additional bird habitat **D**. Beach access is limited to the access at Harbor Glade in order to protect the sensitive coastal habitat **E**. Parking remains along the street, with an entrance improved through the elimination of the guardrail and the addition of rocks, shrubs and grasses **F**. Universally accessible parking is added to the bump-out at the entrance to The Path **G**. Crossing Lafayette Street is made easier by a flashing light and crosswalk **H**.

EMILY BERG, JEFF DAWSON & ALLISON RUSCHP
THE CONWAY SCHOOL
GRADUATE PROGRAM IN SUSTAINABLE
LANDSCAPE PLANNING & DESIGN
WWW.CSLD.EDU
SPRING 2014

LEAD MILLS
CONSERVATION AREA DESIGN
MARBLEHEAD & SALEM, MA
485 LAFAYETTE STREET, SALEM, MA 01970

ALTERNATIVE #3

LEAD MILLS MEADOW CONSERVATION AREA DESIGN

The new design for the Lead Mills Conservation Area accommodates passive recreation for all abilities, with scenic lookouts for visitors and connections to nearby trails.

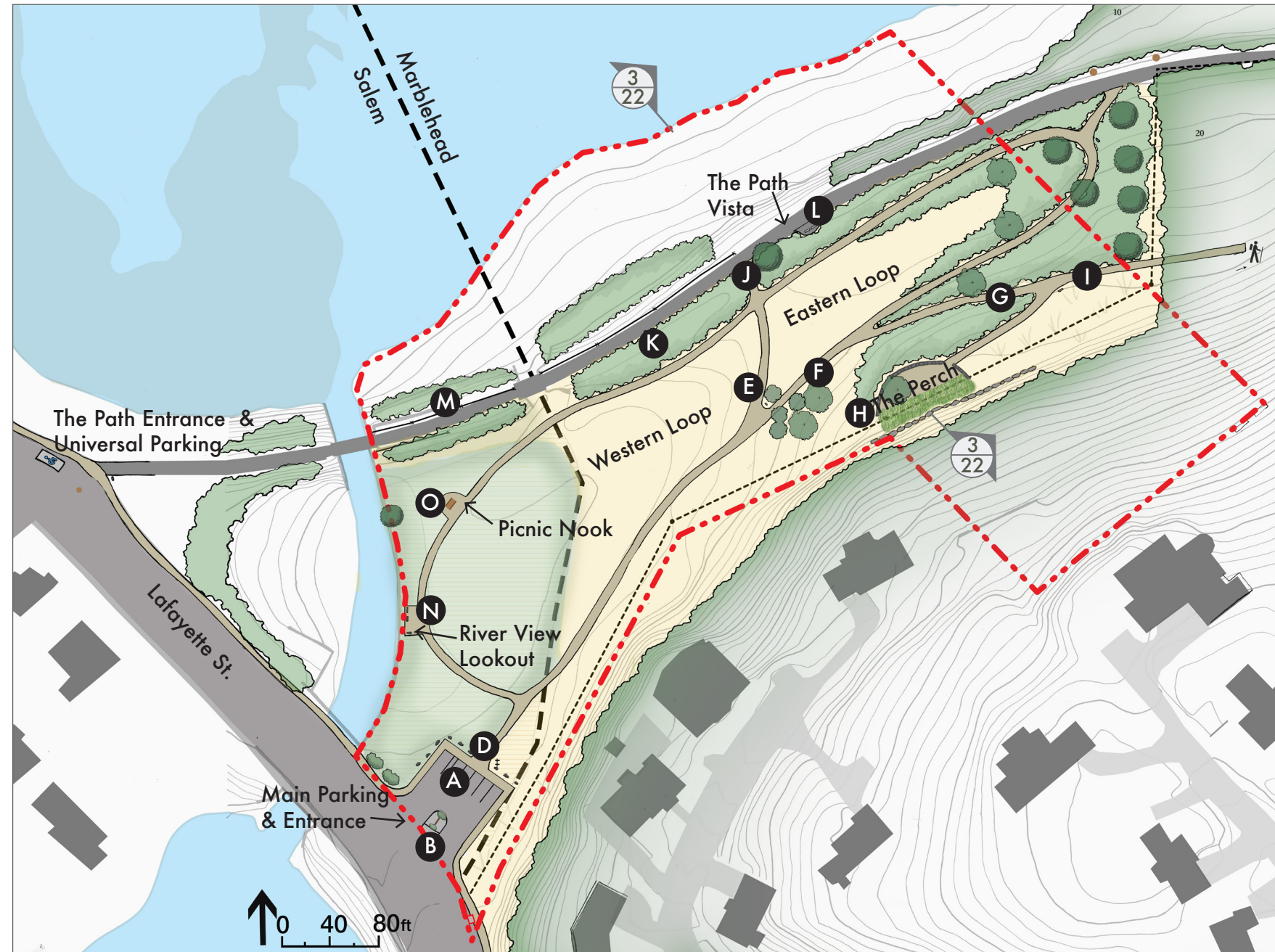

NOT FOR CONSTRUCTION. THIS DRAWING IS PART OF A STUDENT PROJECT AND IS NOT BASED ON A LEGAL SURVEY.

At the entrance to the Lead Mills Conservation Area a new parking area for six cars is created with one universally accessible space **A**. This pull-in has a sign on it to welcome visitors and direct one-way traffic flow. An island in the parking area helps people walk along Lafayette Street **B**. There is an additional universally accessible parking spot added at the entrance to The Path **C**, and the existing bollards are widened to accommodate all visitors.

The trail throughout the site is graded at 5% or less to meet ADA accessibility requirements. This trail is constructed of compacted gravel for easy use by wheelchairs and strollers. A closed circuit trail approximately 1,700 linear feet long is available for strolling through the open space and has spurs that lead to The Path, Wyman Woods, and up to a lookout known as "The Perch."

At the beginning of the trail in Lead Mills Conservation Area, there is a sign that identifies what trails are universally accessible, with the length and grade, and with destination points highlighted **D**. Heading east, the gravel path of the Western Loop reaches a spur that connects to The Path **E**, or continues on to the Eastern Loop that leads through shrubland bird habitat and back around into open meadow **F**. The trail becomes a graded switchback **G** up to, "The Perch" with a rock retaining wall. The Perch has a level area for wheelchair access. The surface is also compacted gravel, and there are five benches for seating and enjoying the beautiful views out to Salem Harbor **H**. A red maple shades the Perch, with a no-mow grass area towards the back. Leaving the Perch, the trail continues east directly into Wyman Woods or rejoins the Eastern Loop trail **I**.

There is wheelchair access to The Path between the Western and Eastern Loops **J**. All other slopes adjacent to The Path have vegetative shrub buffers to encourage people to stay on The Path, stabilize the slopes, and keep the privacy of the site **K**. East of The Path entrance there is a small vista area, with two benches for resting and enjoying the stunning views out to Salem Harbor **L**. The high chain-link fence along the portion of The Path has been shortened to allow for views of the harbor to be seen as people move along The Path **M**.

Along the Forest River on the western loop the River View lookout has four benches **N**. Further along the western loop there is a small picnic area graded for universal access **O**. This western portion of the conservation area over the membrane has been left as it currently is, vegetated with grasses and sedges, and this will be over-seeded with a no/low-mow seed mix.

EMILY BERG, JEFF DAWSON & ALLISON RUSCHP
THE CONWAY SCHOOL
GRADUATE PROGRAM IN SUSTAINABLE
LANDSCAPE PLANNING & DESIGN
WWW.CSLD.EDU
SPRING 2014

LEAD MILLS
CONSERVATION AREA DESIGN
MARBLEHEAD & SALEM, MA
485 LAFAYETTE STREET, SALEM, MA 01970

FINAL DESIGN

1 LEAD MILLS ENTRANCE & PARKING PLAN

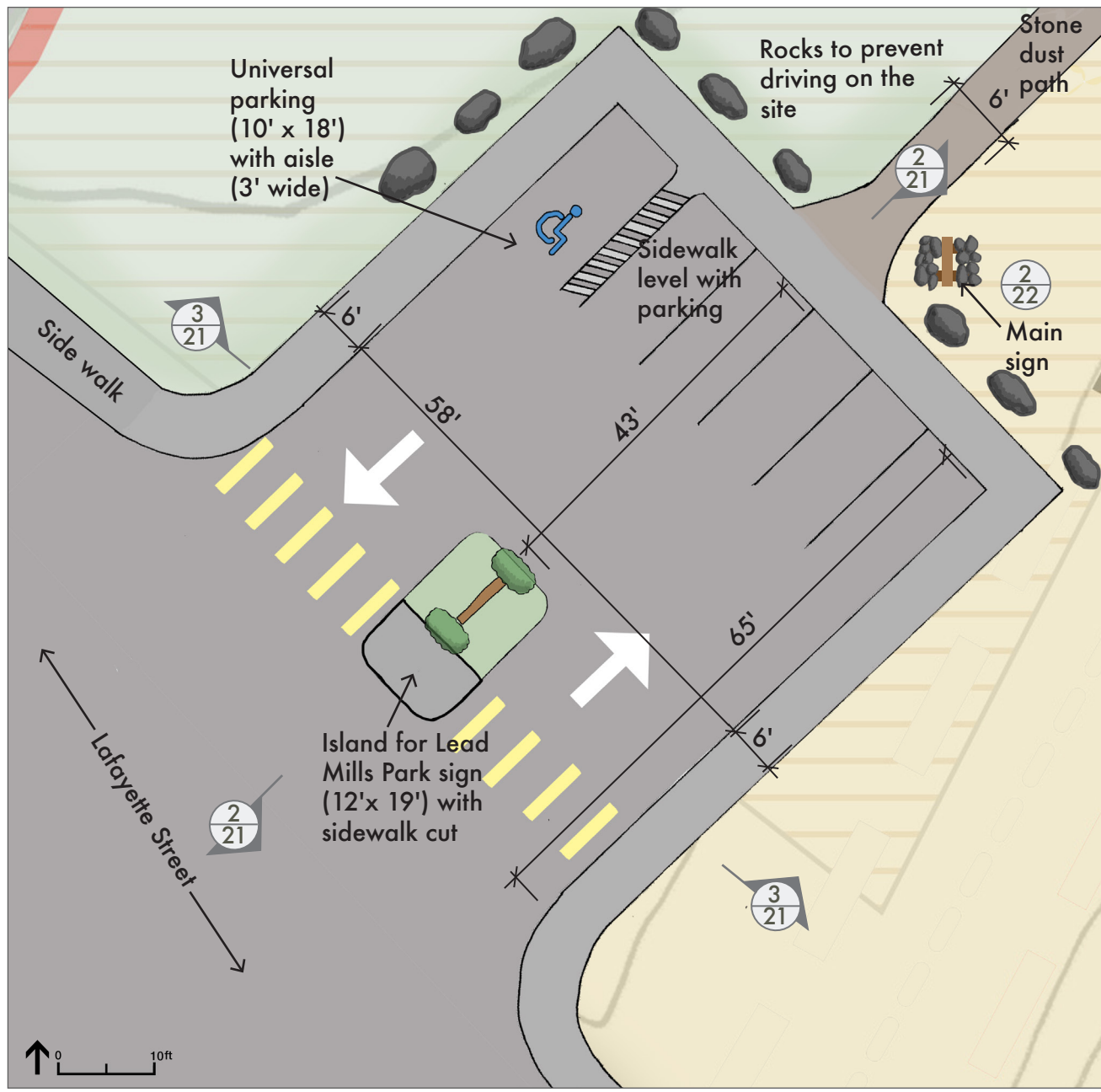

NOT FOR CONSTRUCTION. THIS DRAWING IS PART OF A STUDENT PROJECT AND IS NOT BASED ON A LEGAL SURVEY.

Parking is off Lafayette Street with a one-way entrance and exit accommodating five cars and one universal space. The sidewalk is at the same grade as the parking with a small curb starting at the corners of the lot extending up both sides of Lafayette Street. A large sign at the entrance clearly defines the entrance to the Lead Mills Conservation Area. A trail sign at the start of the trail tells visitors how long the loops are, where other connections can be made and a brief history of the site with warnings against foraging for edibles.

2 LEAD MILLS ENTRANCE & PARKING SECTION

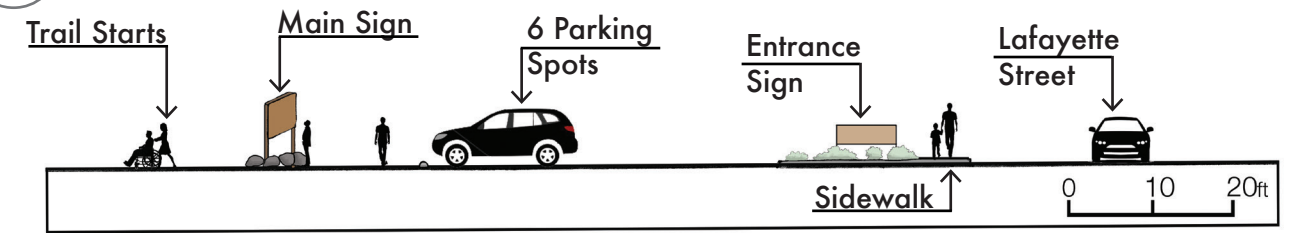

A sidewalk through the entrance island will allow pedestrians to cross the parking area safely. Signs at the entrance to the parking and to the trails informs visitors about the site.

3 LEAD MILLS ENTRANCE & PARKING SECTION

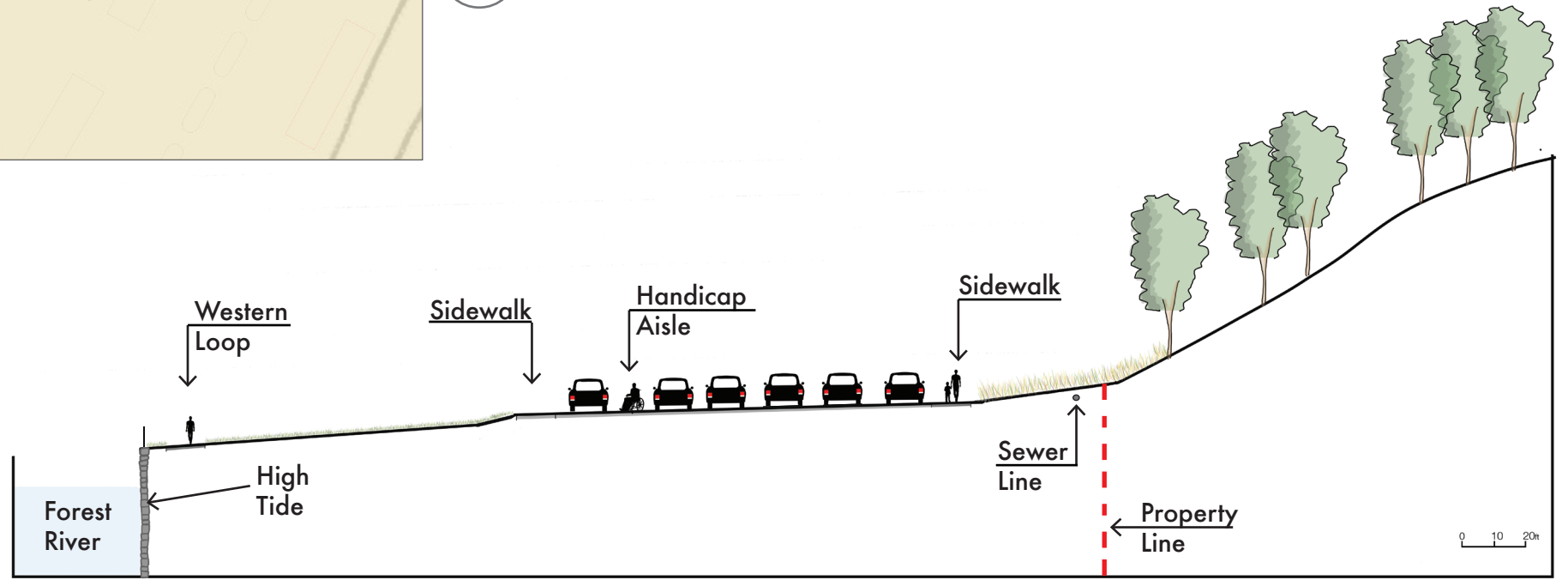

Steep slopes to the south will shade the parking area for part of the day, but stormwater runoff from the slopes may be a problem without proper drainage. Further consultation with a civil engineer will be needed to address these issues.

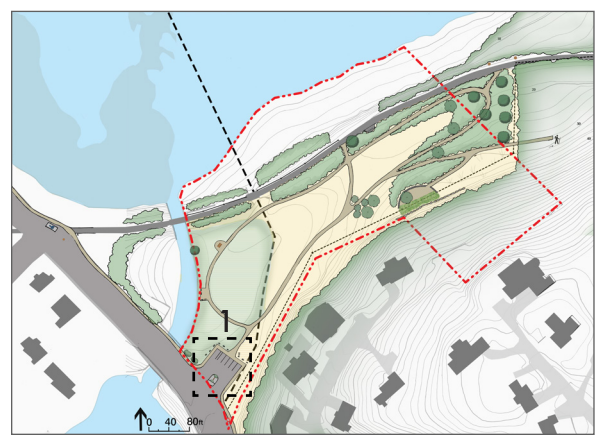

EMILY BERG, JEFF DAWSON & ALLISON RUSCHP
 THE CONWAY SCHOOL
 GRADUATE PROGRAM IN SUSTAINABLE
 LANDSCAPE PLANNING & DESIGN
 WWW.CSLD.EDU
 SPRING 2014

LEAD MILLS
CONSERVATION AREA DESIGN
 MARBLEHEAD & SALEM, MA
 485 LAFAYETTE STREET, SALEM, MA 01970

NOT FOR CONSTRUCTION. THIS DRAWING IS PART OF A STUDENT PROJECT AND IS NOT BASED ON A LEGAL SURVEY.

1 PERCH PLAN

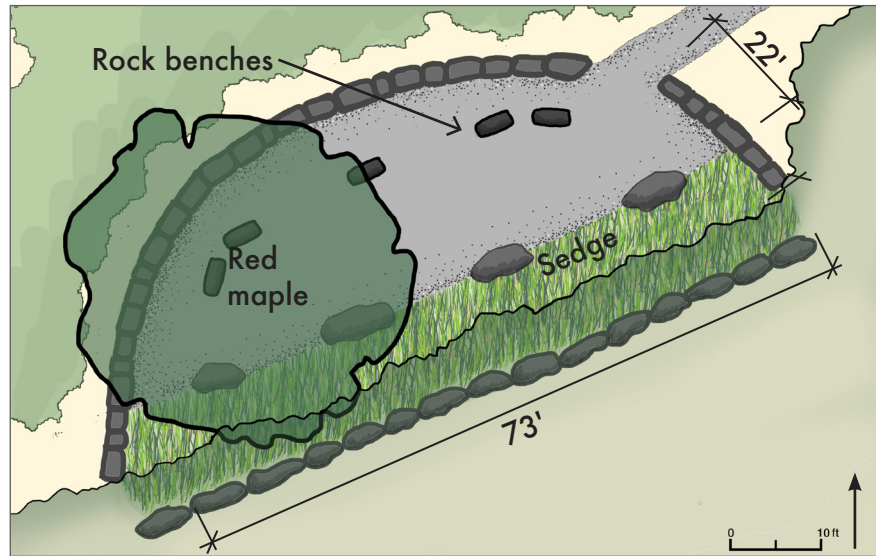

The Perch is a lookout in the southeast corner of the site with expansive views into Salem Harbor and the rest of the site. A universal trail winds up to the small stone retaining wall that encloses the space in an arc. Granite rocks are placed around for viewing of the harbor with additional seats for small groups to mingle. A red maple tree partially shades the perch on hot summer days.

2 THE PATH VISTA PLAN

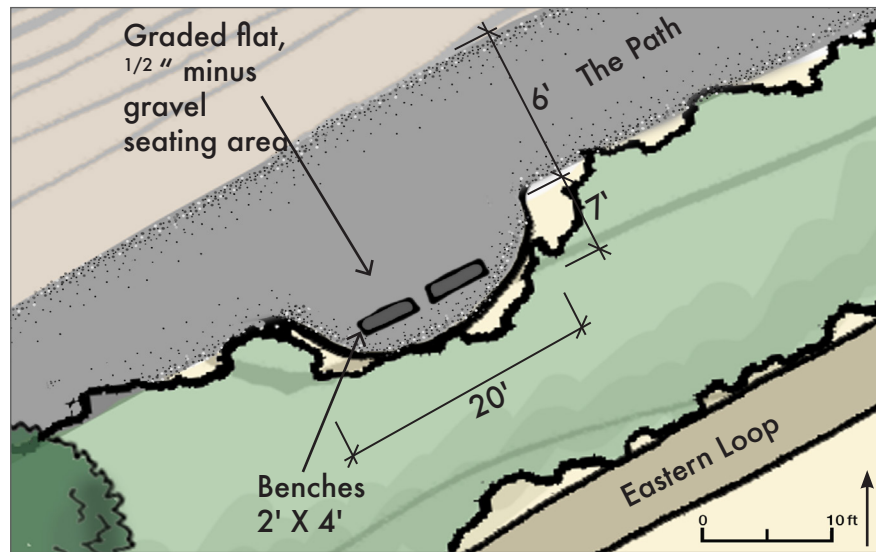

A small bump-out along The Path provides a resting space for visitors to enjoy the views out to Salem Harbor. The spot is universally accessible from both the site and The Path.

3 PERCH AND LOOKOUT SECTION

The whole site is universally accessible with low grade trails taking visitors to destination spots such as the perch and The Path Vista.

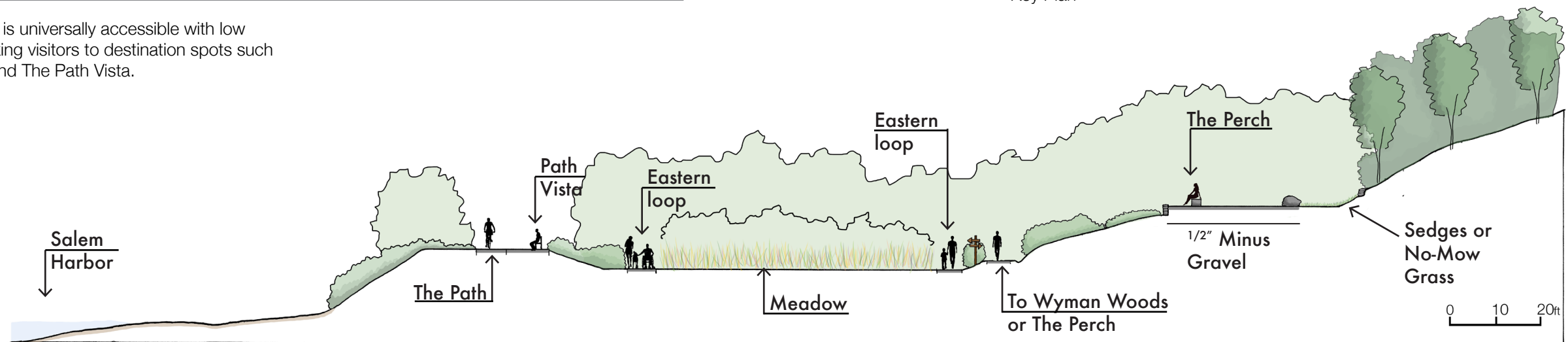

THE PERCH

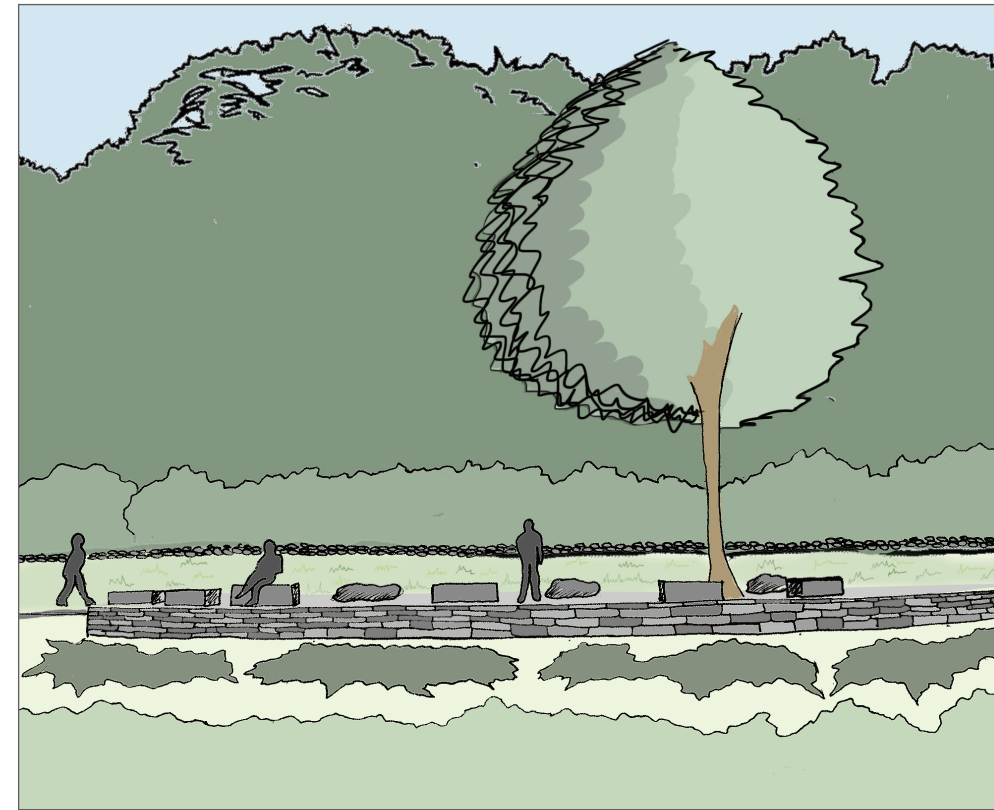

The Perch will be a nice place to hang out under the shade of the red maple while taking in the views of Salem Harbor.

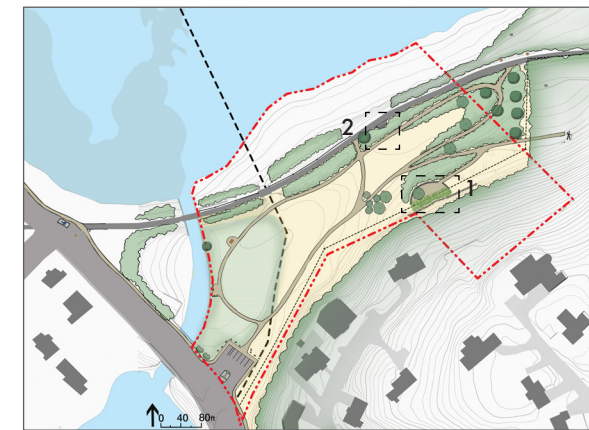

Key Plan

NOT FOR CONSTRUCTION. THIS DRAWING IS PART OF A STUDENT PROJECT AND IS NOT BASED ON A LEGAL SURVEY.

RIVER VIEW LOOKOUT

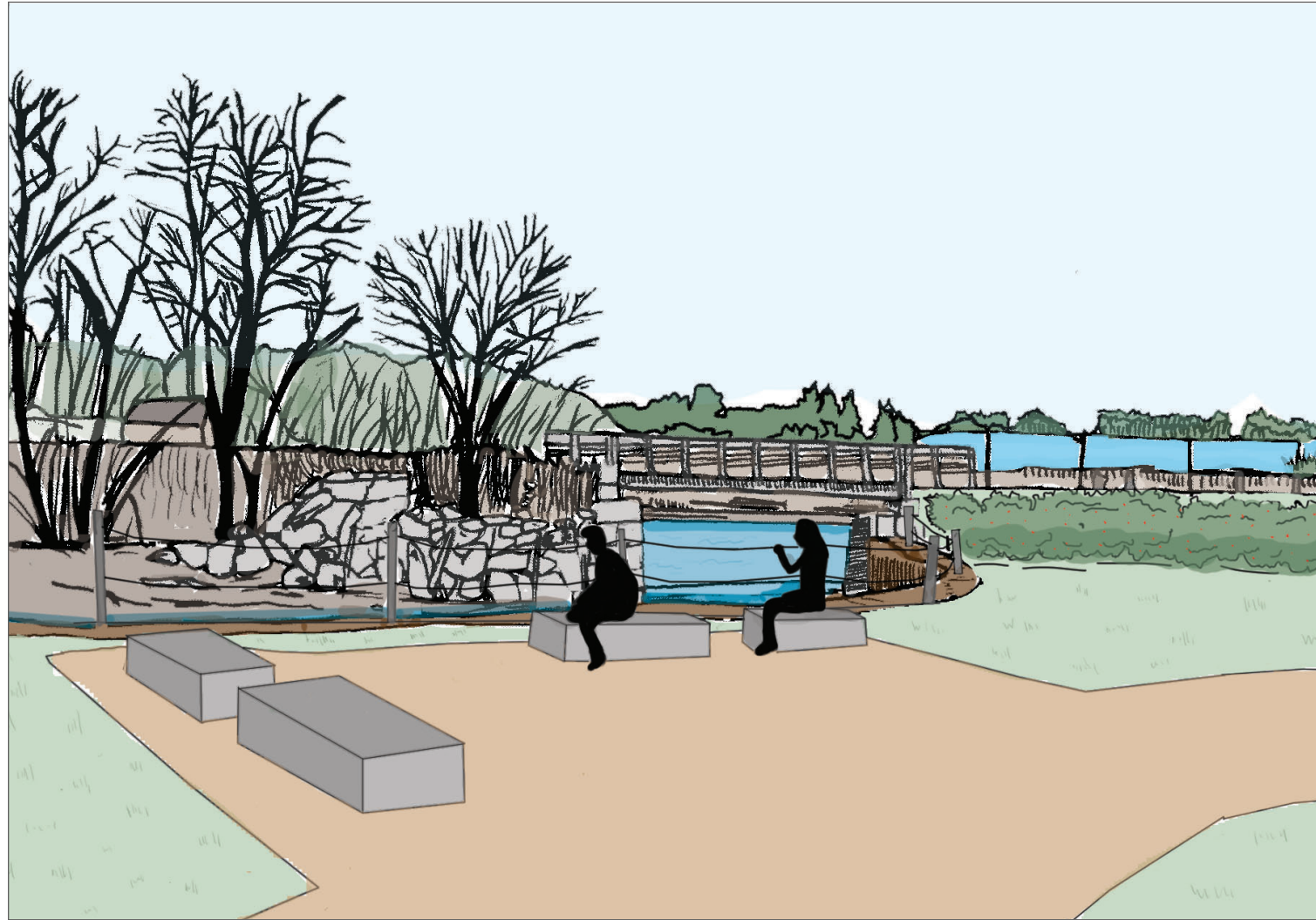

Sitting at the River View Lookout, visitors have 360-degree views of the site, the Forest River, and Salem Harbor.

1 PICNIC NOOK SECTION

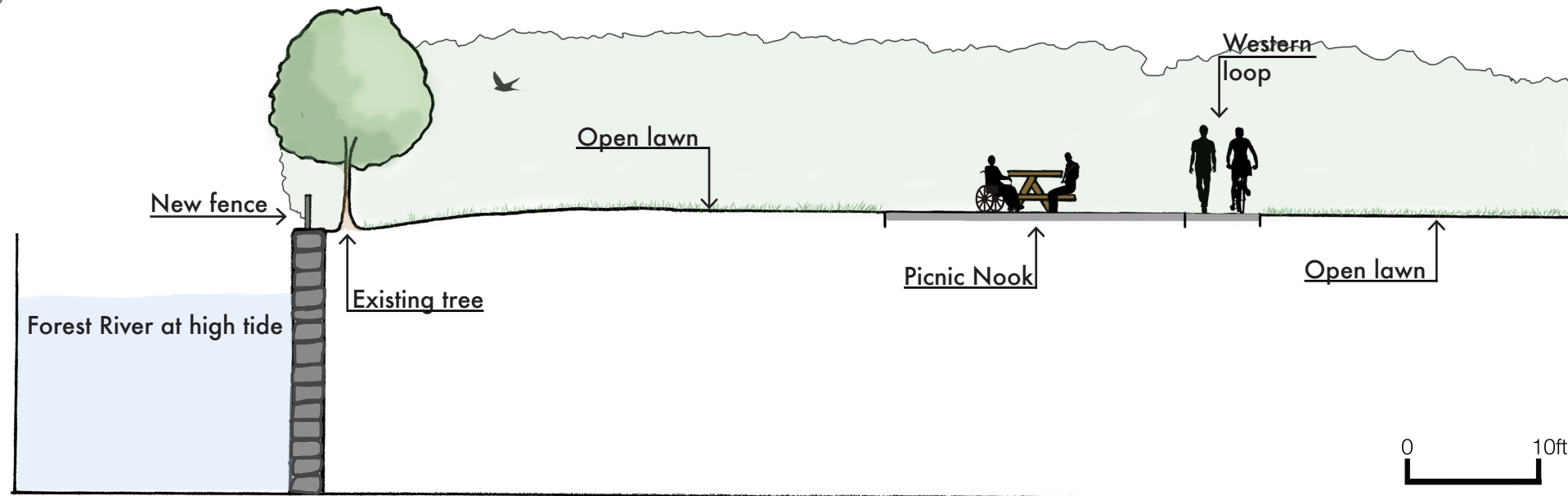

The Picnic Nook is nestled near the Forest River, buffered by an existing tree and shrubs along The Path.

2 RIVER VIEW LOOKOUT PLAN

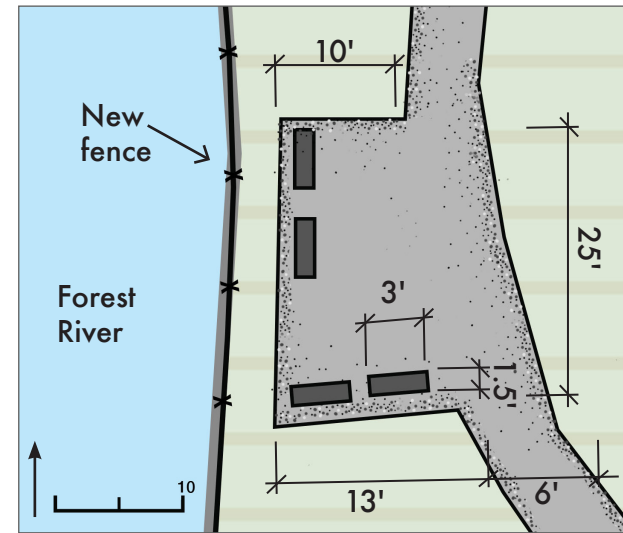

A resting spot along the Forest River allows visitors to enjoy the views of the Forest River, Salem Harbor, and the conservation area. A new fence is built along the stone wall to increase safety.

3 PICNIC NOOK PLAN

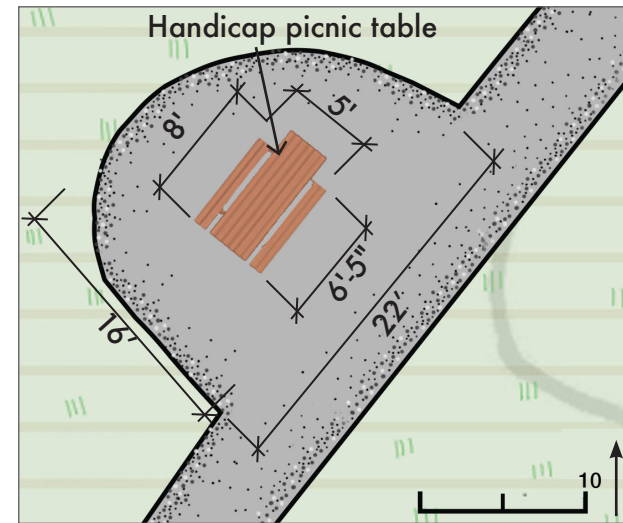

A universally accessible picnic table just off the western loop trail brings visitors close to the Forest River.



Key Plan

LEAD MILLS
CONSERVATION AREA DESIGN
MARBLEHEAD & SALEM, MA
485 LAFAYETTE STREET, SALEM, MA 01970

EMILY BERG, JEFF DAWSON & ALLISON RUSCHP
THE CONWAY SCHOOL
GRADUATE PROGRAM IN SUSTAINABLE
LANDSCAPE PLANNING & DESIGN
WWW.CSLD.EDU
SPRING 2014

GRADING PLAN

In order to make the new paths through Lead Mills Park universally accessible, regrading will be needed.

NOT FOR CONSTRUCTION. THIS DRAWING IS PART OF A STUDENT PROJECT AND IS NOT BASED ON A LEGAL SURVEY.



The new contours reflect slopes of 5% or less across required distances to create accessible trails.

The trails work with the natural contours of the land to require minimal earth moving for universally accessible grades.

Using cut-and-fill, the trail is built into the hillside. The retaining wall is two feet tall (+/-) and tapers into the hill to meet the grade.

Fill is used to support the fork in the trail. The drainage basin is divided into two low-draining basins, where water collects and irrigates the planted vegetation.

GRADING PLAN

**LEAD MILLS
CONSERVATION AREA DESIGN**
MARBLEHEAD & SALEM, MA
485 LAFAYETTE STREET, SALEM, MA 01970

EMILY BERG, JEFF DAWSON & ALLISON RUSCHP
THE CONWAY SCHOOL
GRADUATE PROGRAM IN SUSTAINABLE
LANDSCAPE PLANNING & DESIGN
WWW.CSLD.EDU
SPRING 2014

PLANTING PLAN

A large meadow and lawn provide an open landscape, and shrubs around the trail increase biodiversity and provide shelter for migratory birds. A delightful sensory experience is created for people strolling through the Lead Mills Conservation Area.

NOT FOR CONSTRUCTION. THIS DRAWING IS PART OF A STUDENT PROJECT AND IS NOT BASED ON A LEGAL SURVEY.

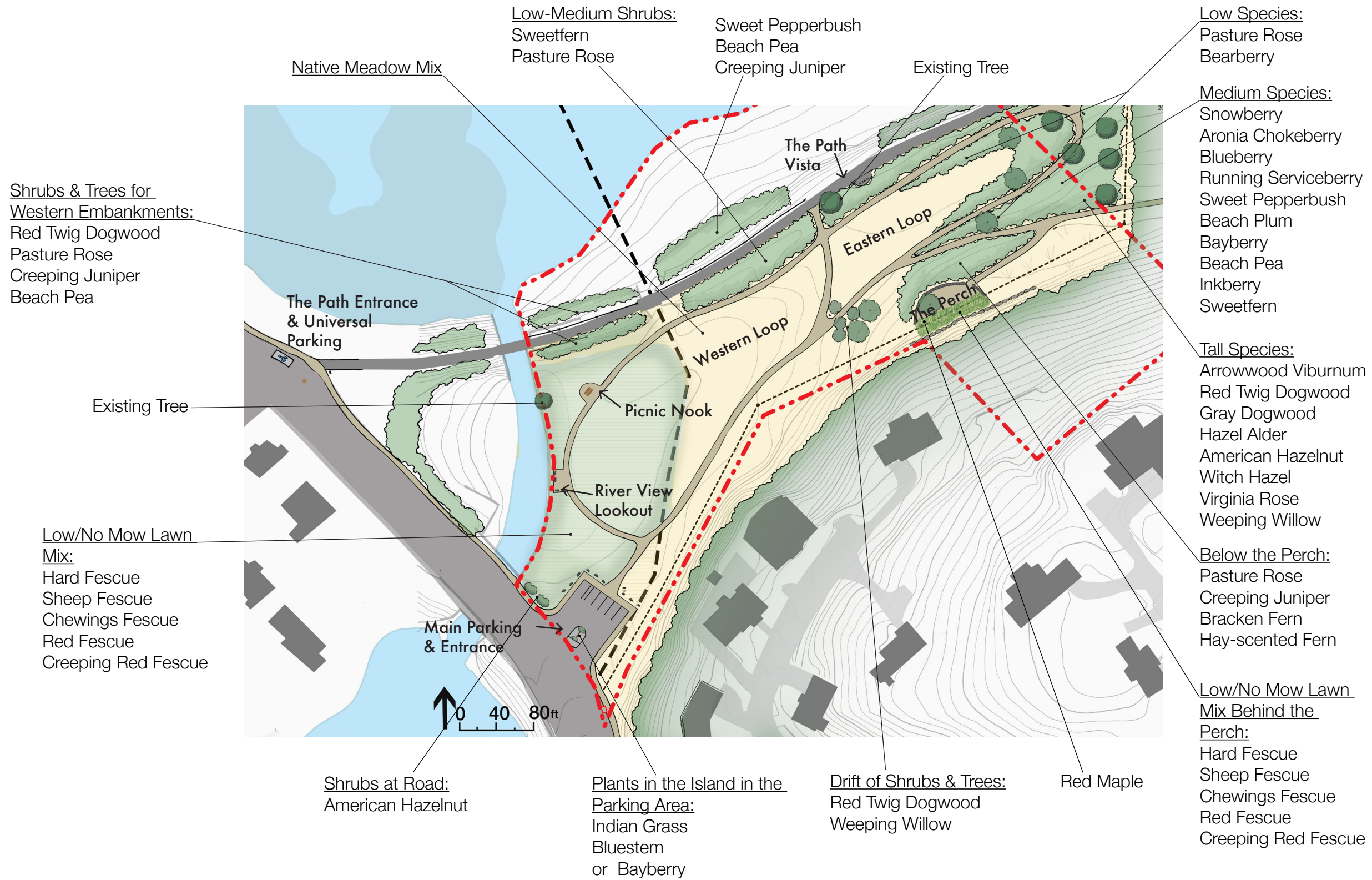

*Plant species in a mix from low to high to prevent desirable views from being blocked in front of the perch.

EMILY BERG, JEFF DAWSON & ALLISON RUSCHP
THE CONWAY SCHOOL
GRADUATE PROGRAM IN SUSTAINABLE
LANDSCAPE PLANNING & DESIGN
WWW.CSLD.EDU
SPRING 2014

LEAD MILLS
CONSERVATION AREA DESIGN
MARBLEHEAD & SALEM, MA
485 LAFAYETTE STREET, SALEM, MA 01970

PLANTING PLAN

*These plants were chosen for their salt tolerance, sizes, seasonal interest, and habitat attributes.

PLANTING DETAILS

Common Name	Scientific Name	Radius	Height	Quantity
Low Shrubs				
Common Bearberry	<i>Arctostaphylos uva-ursi</i>	3-6'	0.5-1'	515
Pasture Rose	<i>Rosa carolina</i>	3'	3'	1492
Creeping Juniper	<i>Juniperus horizontalis</i>	3-9'	1'	674
Bracken Fern	<i>Pteridium aquilinum</i>	8'	2-6'	127
Hay-scented Fern	<i>Dennstaedtia punctilobula</i>	3"	10"	180
Beach Pea	<i>Lathyrus japonica</i>	1'	1'	Seed Mix
Medium Shrubs				
Running Serviceberry	<i>Amelanchier stolonifera</i>	4-5'	4-5'	309
Bayberry	<i>Myrica pensylvanica</i>	5-10'	5-10'	190
Sweet Pepperbush	<i>Clethra alnifolia</i>	3-8'	4-6'	564
Inkberry	<i>Ilex glabra</i>	6'	6'	258
Beach Plum	<i>Prunus maritima</i>	1-8'	5'	193
Sweetfern	<i>Comptonia peregrina</i>	4-8'	2-5'	564
Blueberry	<i>Vaccinium angustifolium</i>	1.5'	1.5'	515
Snowberry	<i>Gaultheria antipoda</i>	3'	3'	515
Virginia Rose	<i>Rosa virginiana</i>	3'	3'	516
Tall Shrubs				
Arrowwood Viburnum	<i>Viburnum dentatum</i>	6-10'	6-10'	155
American Hazelnut	<i>Corylus americana</i>	8-13'	10-16'	122
Red Chokeberry	<i>Aronia arbutifolia</i>	9'	9'	172
Trees				
Red Maple	<i>Acer rubrum</i>	39'	20'	1
Gray Dogwood	<i>Cornus racemosa</i>	10-15'	10-15'	103
Hazel Alder	<i>Alnus incana subsp. rugosa</i>	15-25'	15-25'	15
Witch Hazel	<i>Hamamelis virginiana</i>	15-20'	15-20'	77
Serviceberry	<i>Amelanchier canadensis</i>	15-20'	25-30'	309
Red Twig Dogwood	<i>Cornus sericea</i>	6-9'	8-12'	309
Weeping Willow	<i>Salix babylonica</i>	30'	32'	5
Seed Mix				
Hard Fescue	<i>Festuca brevipila</i>			Seed Mix
Sheep Fescue	<i>Festuca ovina</i>			Seed Mix
Chewings Fescue	<i>Festuca rubra subs. fallax</i>			Seed Mix
Red Fescue	<i>Festuca rubra</i>			Seed Mix
Creeping Red Fescue	<i>Festuca rubra var. rubra</i>			Seed Mix

MEADOW ESTABLISHMENT (TYPICAL)

An established meadow can require less annual maintenance than a lawn, reduce stormwater runoff, and promote biodiversity. A diverse meadow can take a few years to create with a more intense maintenance regime in the beginning to help deplete the existing seed bank and allow for the desired plants to take root. Due to the site's history of lead contamination, methods to establish the meadow should not disturb the ground surface where the remediation and stabilization has taken place.

TO ESTABLISH LAWN/MEADOW

- October: mow lawn and meadow area late in the month.
- Seed in late winter/early spring while the ground is still frozen.
- Rely on spring rains to initiate and irrigate seeds.

MEADOW MIX

Prairie Moon Nursery's *Grand Diversity Mixed Height Prairie Seed Mix* offers a hundred species that include a variety of flowers, which bloom from early spring to fall and can handle a range of soil conditions. This mix is particularly supportive of birds and butterflies.

1 TREE AND SHRUB PLANTING DETAIL (TYPICAL)

NOT TO SCALE

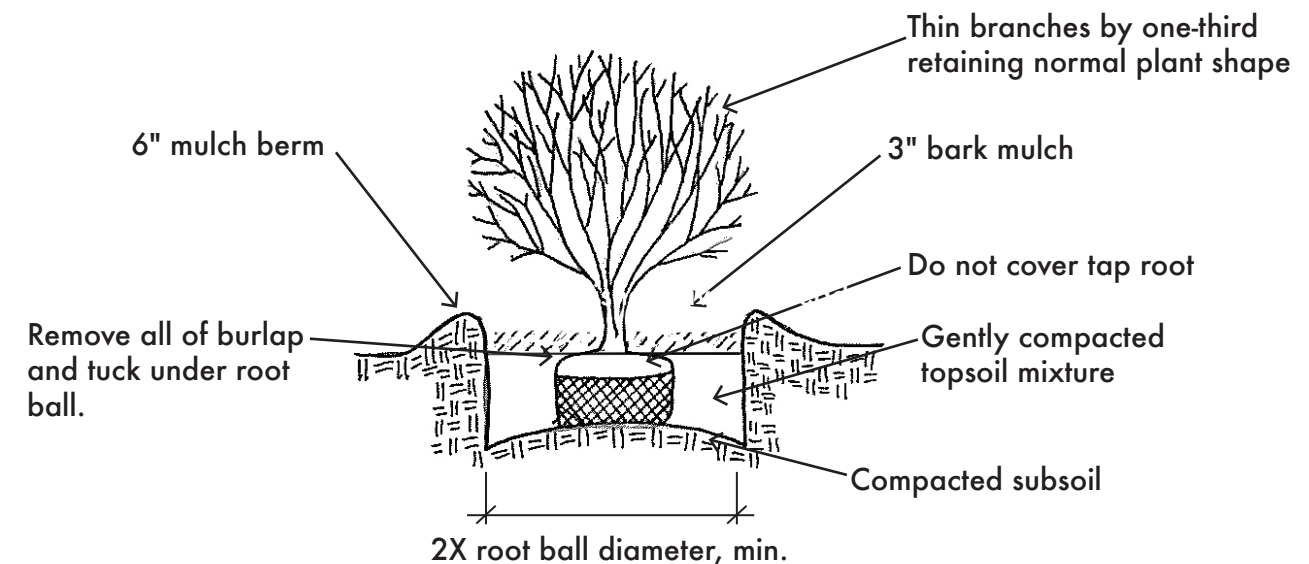

NOTE: This detail calls for tamping subsoil to create a firm base upon which to place the shrub or tree root ball. The amended existing soil is backfilled carefully around the roots to support the plant and gently compacted to prevent air pockets from forming. A generous soaking after back filling is recommended to remove remaining air pockets around the roots. Prune back one-third of the foliage to stimulate root growth, taking care to retain shape. Do not use fertilizers. Water frequently for first season.

NOT FOR CONSTRUCTION. THIS DRAWING IS PART OF A STUDENT PROJECT AND IS NOT BASED ON A LEGAL SURVEY.

INVASIVE PLANT MANAGEMENT

Invasive species management is a complex issue that requires comprehensive knowledge, intensive labor, monitoring, humility, and care. Further research should be done before dealing with the Oriental bitterweet and Japanese knotweed found at Lead Mills Conservation Area.

ABOUT ORIENTAL BITTERSWEET

Celastrus orbiculatus

Oriental bitterweet (also known as Asian or Asiatic bitterweet) is a deciduous vine native to Japan, Korea, and parts of China. It commonly twines around other shrubs, trees, or fences, and can reach up to 60 feet in height. Bittersweet grows in a variety of terrestrial environments and likes full sunlight. It dominates indigenous plant communities through rapid reproduction, dispersal, and growth rate. At the Lead Mills Conservation Area, it is found growing along the chain-link fence at the bike path. The fence is meant to keep people from moving onto the steep embankment, but the bitterweet, especially in spring, blocks the views of the water from the bike path.

MANAGEMENT

Mechanical Methods:

As with all invasive plant species management, control of Oriental bitterweet requires extensive monitoring, and often a multi-year commitment to the project. Regular cutting to the ground over several growing seasons can be a measure of control. Vines should be cut as close to the root collar as possible. Eventually the root stock expends all of its stored energy, leaving only the seed banks to deal with.

Chemical Methods:

Herbicides such as Round-Up are sometimes used to manage bitterweet. If used, quickly establish alternative native plant cover, such as Clematis virginiana, after treatment to prevent Oriental bitterweet from reestablishing.

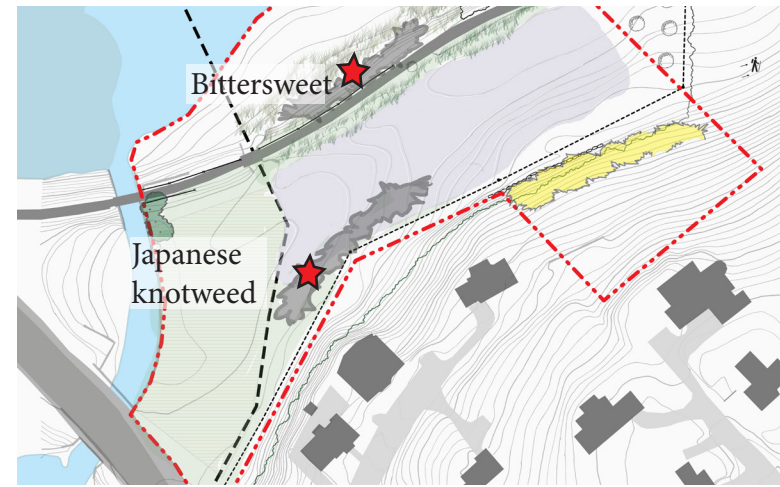

Locations of invasive plant species at Lead Mills Conservation Area.



Bittersweet found along the chainlink fence and bike path.



Japanese knotweed found in the southeast quadrant of the site.

ABOUT JAPANESE KNOTWEED

Polygonum cuspidatum

Japanese knotweed is an upright, shrub-like herbaceous perennial that can grow up to 10 feet tall. Once established, it spreads via rhizomes or runners underground that can reach up to 30 feet in length. It is found in the southwest quadrant of the Lead Mills Conservation Area among other herbaceous perennials. Japanese knotweed grows primarily in high light environments, emerging in early spring.

MANAGEMENT

Mechanical Methods:

Digging and cutting are appropriate for controlling smaller, younger stands of Japanese knotweed, especially in environmentally sensitive areas. The entire plant, including roots and runners must be removed with a digging tool. With cutting, the shoots must be cut as close to the ground as possible, and cutting is most effective when done three or more times per growing season. The cut plant parts must be bagged and disposed of properly to prevent further spread.

Chemical Methods:

The cut-stem method is often effective with chemical treatments. A stand of Japanese knotweed may require three to five years of repeated chemical treatment before knotweed is effectively controlled.

RECOMMENDATIONS

Herbicide application is always hazardous, particularly when working with concentrated agents. Trained, certified applicators should be employed for such work. Special permits are required to perform this work at Lead Mills Conservation Area.

Herbicides can have serious environmental and medical impacts, and yet adequate controls for invasive species are difficult to achieve. Herbicide should not be applied without planning and continued monitoring of the treated areas.

With consideration to the Lead Mills Conservation Area and the maintenance schedule of the Marblehead Conservancy, it is the recommendation of this team to first utilize mechanical methods to treat areas of invasive species. In the future, if it is decided to put the effort into chemical management, we recommend working in consultation with regional experts to develop appropriate protocols.

CONSTRUCTION DETAILS

1 UNIVERSALLY ACCESSIBLE TRAIL DETAIL (TYPICAL) NOT TO SCALE

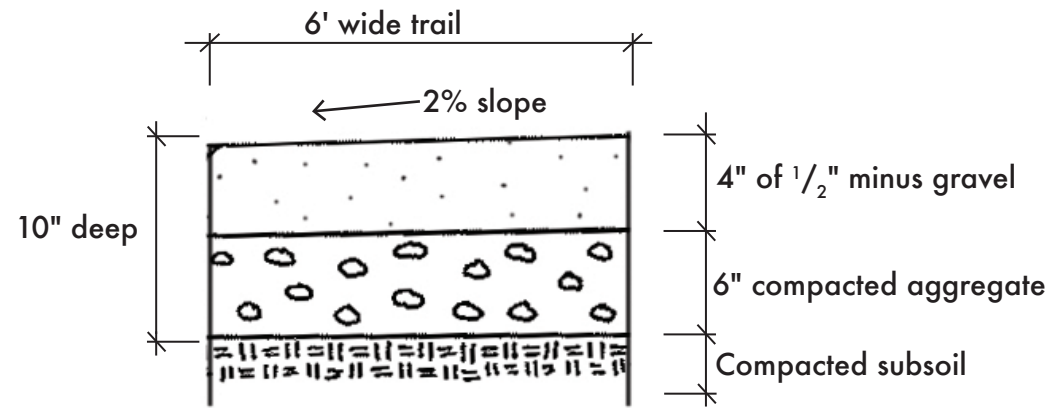

NOTE: This detail calls for excavation 12 feet wide by 10 inches deep. This will need to be done carefully over areas where the membrane is present. The existing soil is then compacted before adding aggregate and then gravel to make the 6-foot-wide trail. The trail needs to be graded to a 5% or less longitudinal slope in order to accommodate universal access with a 2% cross slope to drain water.

2 UNIVERSALLY ACCESSIBLE ON SLOPE WITH UPHILL SWALE DETAIL (TYPICAL) NOT TO SCALE

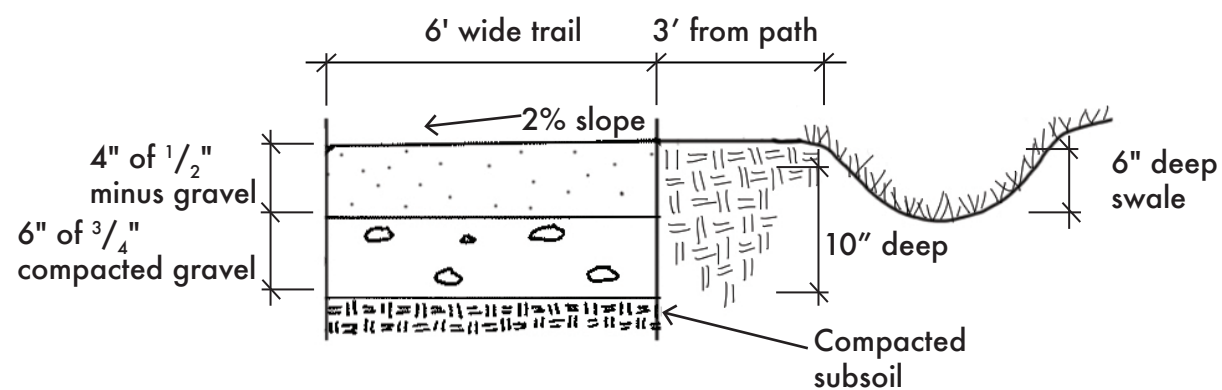

NOTE: This detail incorporates a swale for areas that climb a slope. This detail calls for excavation 12 feet wide by 10 inches deep. The existing soil is then compacted before adding in aggregate and then lastly the compacted gravel to make the 6-foot-wide trail. The trail needs to be graded to a 5% longitudinal slope in order to accommodate universal access with a 2% cross slope to drain water. Three feet from the trail on the uphill side, a 6 inch deep swale collects water running from uphill to keep the trail from being washed out.

3 PAVING ASPHALT PARKING OVER MEMBRANE (TYPICAL) NOT TO SCALE

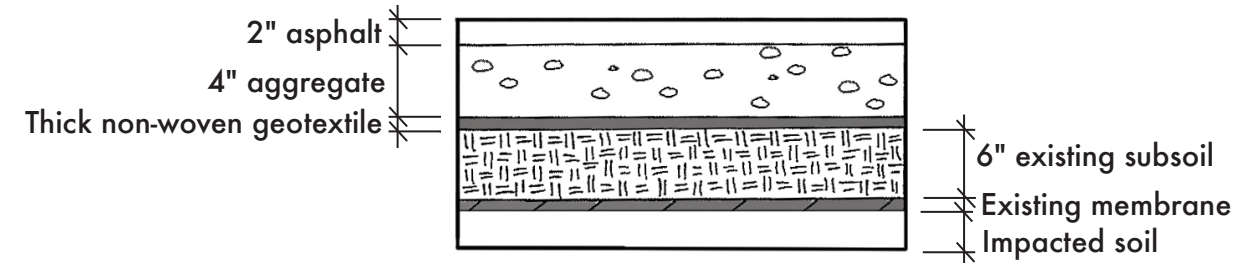

NOTE: This detail includes a thick non-woven geotextile to protect the existing membrane from damage. The geotextile is laid on top of existing subsoil. Care must be taken when excavating this area in order to not disturb the existing membrane.

4 RIVER WALL FENCE DETAIL (TYPICAL) NOT TO SCALE

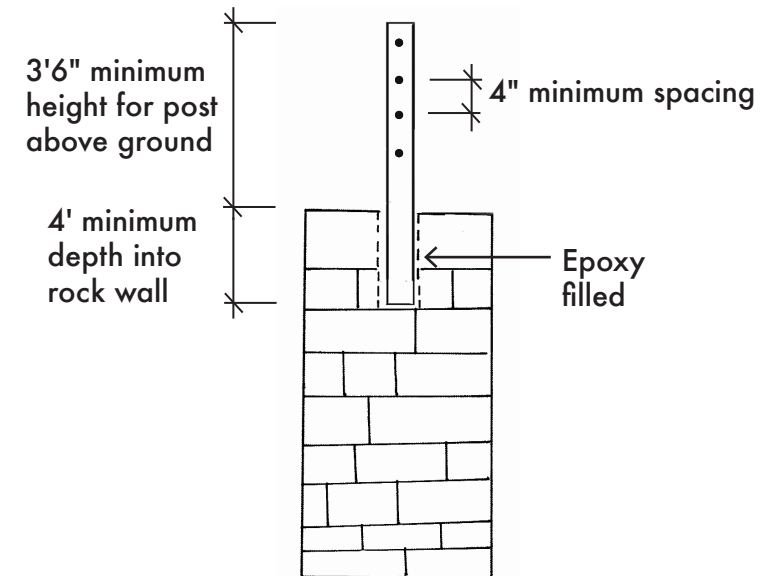

NOTE: This detail shows the construction of a new fence for the Forest River wall. Holes will be drilled into the existing stone wall at a minimum of 4 feet deep then filled with epoxy followed by the fence post. The minimum distance between each fence rail or cable should be 4 inches.

NOT FOR CONSTRUCTION. THIS DRAWING IS PART OF A STUDENT PROJECT AND IS NOT BASED ON A LEGAL SURVEY.

EMILY BERG, JEFF DAWSON & ALLISON RUSCHP
THE CONWAY SCHOOL
GRADUATE PROGRAM IN SUSTAINABLE
LANDSCAPE PLANNING & DESIGN
WWW.CSLD.EDU
SPRING 2014

LEAD MILLS
CONSERVATION AREA DESIGN
MARBLEHEAD & SALEM, MA
485 LAFAYETTE STREET, SALEM, MA 01970

CONSTRUCTION DETAILS

MAPS & SIGNS

Currently the Lead Mills Conservation Area and The Path have no signs to indicate length or the connections to other trails in the area. There are existing signs at the entrances to Wyman Woods and the Forest River conservation areas, but they only inform the visitor of the name and total acreage.

It is important to place signs at trail entrances and spurs informing visitors where they are located, the length of trails, and any specific information about the trail (poison ivy nearby etc.). The main trail sign at the entrance to the conservation area should highlight destinations and include accessibility information such as the average slope and cumulative elevation. Signs can also educate visitors about wildlife, site history, and the remediation process, and warn them against foraging.

NOT FOR CONSTRUCTION. THIS DRAWING IS PART OF A STUDENT PROJECT AND IS NOT BASED ON A LEGAL SURVEY.

1 PATH INTERSECTION SIGN DESIGN (TYPICAL) NOT TO SCALE

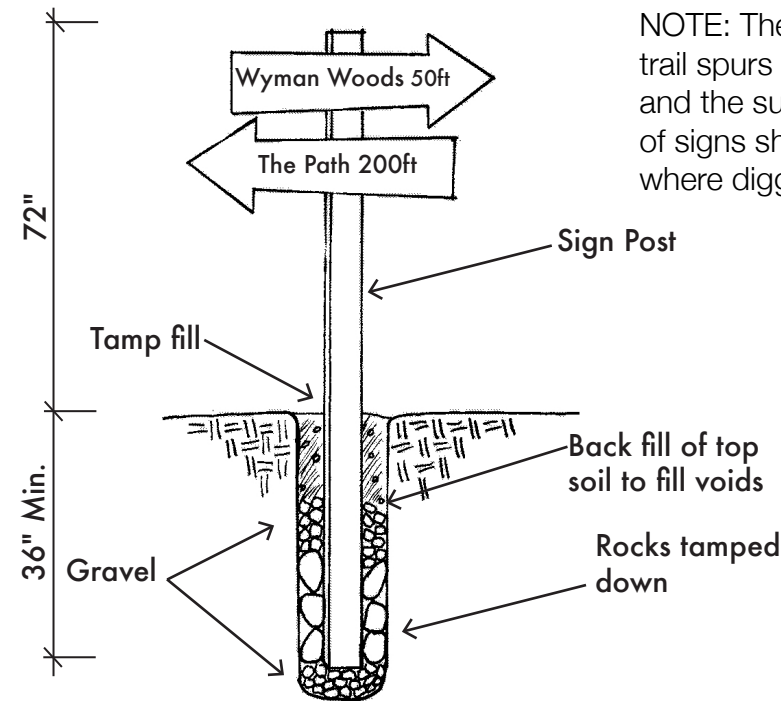

NOTE: These signs should be placed at all trail spurs to direct visitors around the site and the surrounding area. The placement of signs should be off the membrane area where digging into the substrate is allowed.

2 MAIN TRAIL SIGN DETAIL NOT TO SCALE

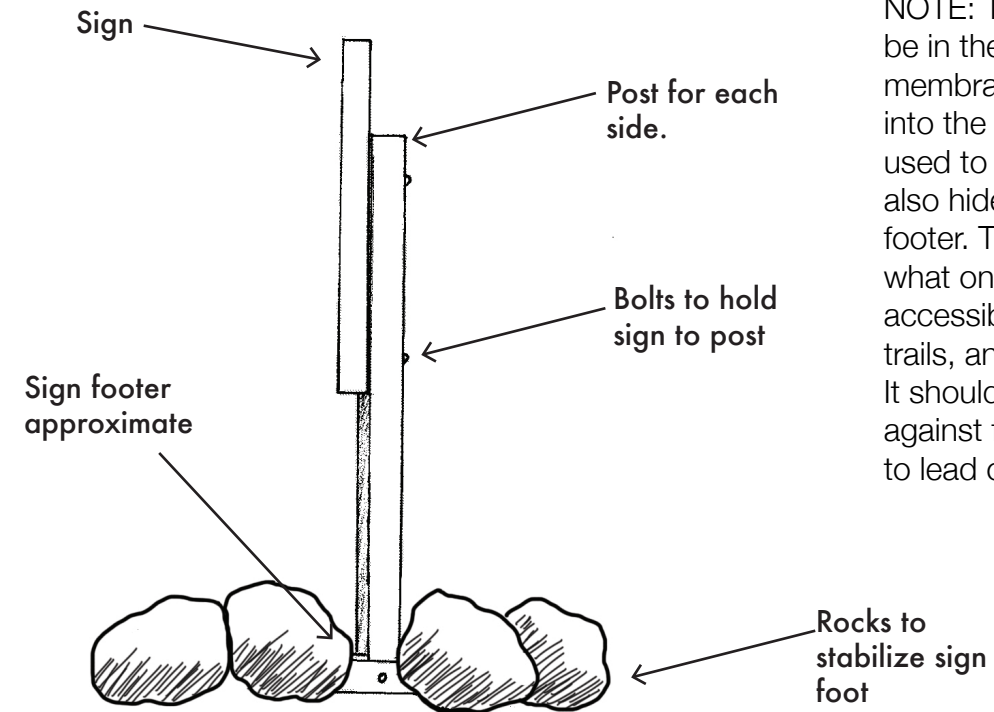

NOTE: The main trail sign will be in the area with the existing membrane so it cannot be dug into the ground. Large rocks are used to stabilize the sign and also hide the large horizontal footer. The sign should indicate what on the site is universally accessible, the grade of the trails, and all destination points. It should also warn visitors against foraging on the site due to lead contaminates.

This existing sign made for the Lead Mills Conservation Area will be placed at the start of the loop trail near the new parking area. Information about trail entrances to Wyman Woods and Forest River, and accessibility information will be added on another sign or a new entrance sign will be created.

LEAD MILLS CONSERVATION AREA DESIGN
MARBLEHEAD & SALEM, MA
 485 LAFAYETTE STREET, SALEM, MA 01970
EMILY BERG, JEFF DAWSON & ALLISON RUSCHP
 THE CONWAY SCHOOL
 GRADUATE PROGRAM IN SUSTAINABLE
 LANDSCAPE PLANNING & DESIGN
 WWW.CSLD.EDU
 SPRING 2014

SIGN DETAILS

FENCE REMODEL DETAIL

The six-foot-high chainlink fence along The Path is in need of reinvention. The fence keeps people from walking down the eroding beach embankment but its height blocks views into Salem Harbor. Reducing the height of the fence will enhance the pedestrian and bicyclist experience along The Path and provide views into Salem Harbor. The existing fence post should remain so no new digging is done into the contaminated soil. To the right are some examples of fence remodeling techniques.

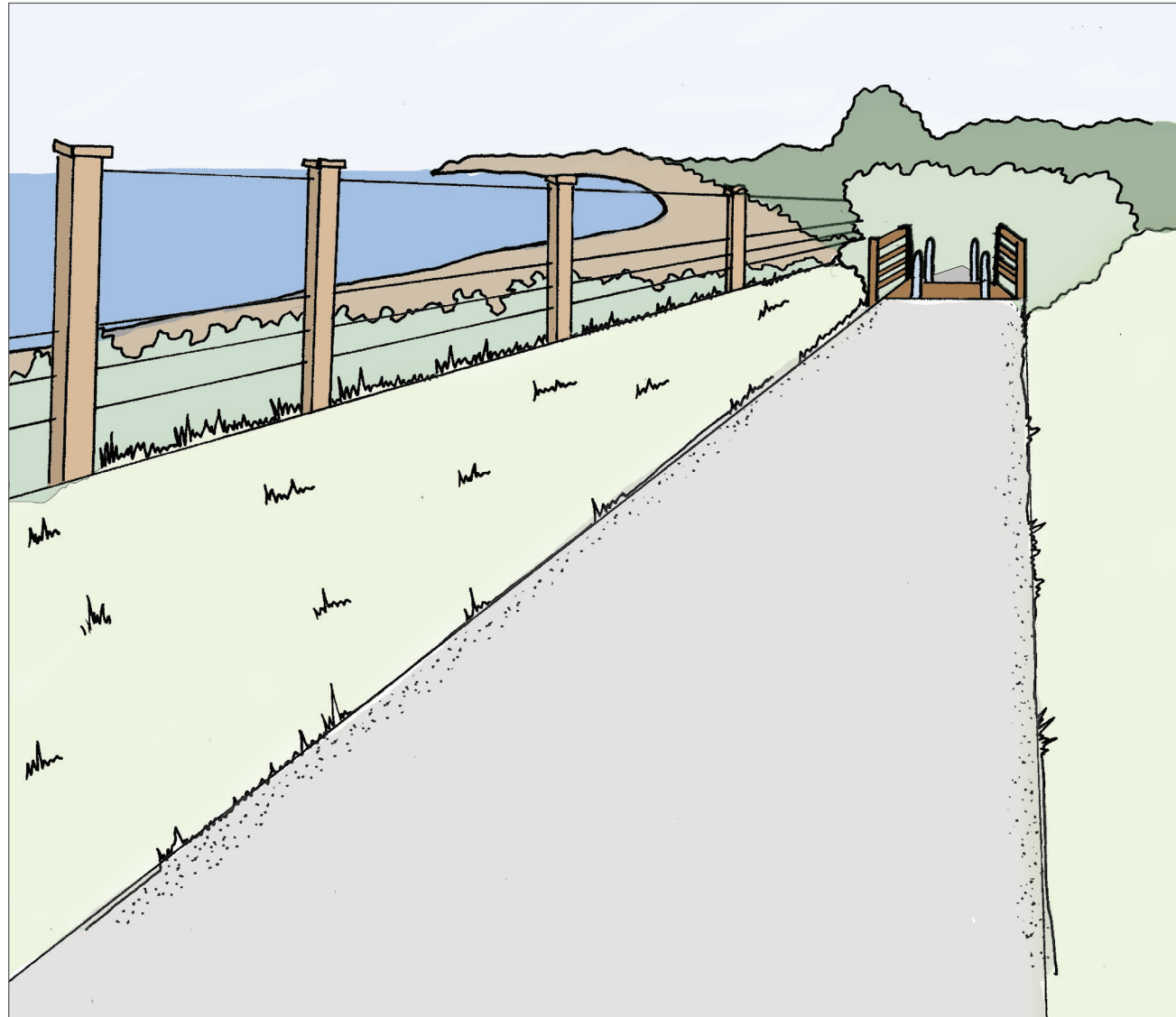

A new fence will open up views into Salem Harbor while still prohibiting access down the sensitive slope.

NOT FOR CONSTRUCTION. THIS DRAWING IS PART OF A STUDENT PROJECT AND IS NOT BASED ON A LEGAL SURVEY.

1 WOOD PANEL FENCE DETAIL (TYPICAL) NOT TO SCALE

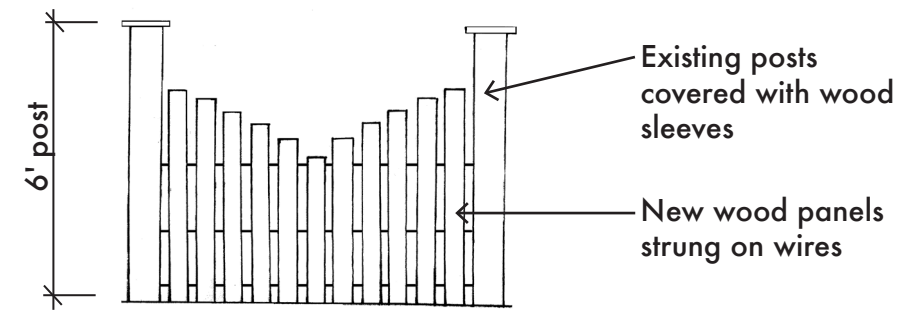

NOTE: Wood sleeves are added around the existing posts with new wood panels strung on wire ranging in heights to mimic waves and increase visibility.

2 WOOD PANEL POST WITH LOWER CHAIN LINK (TYPICAL) NOT TO SCALE

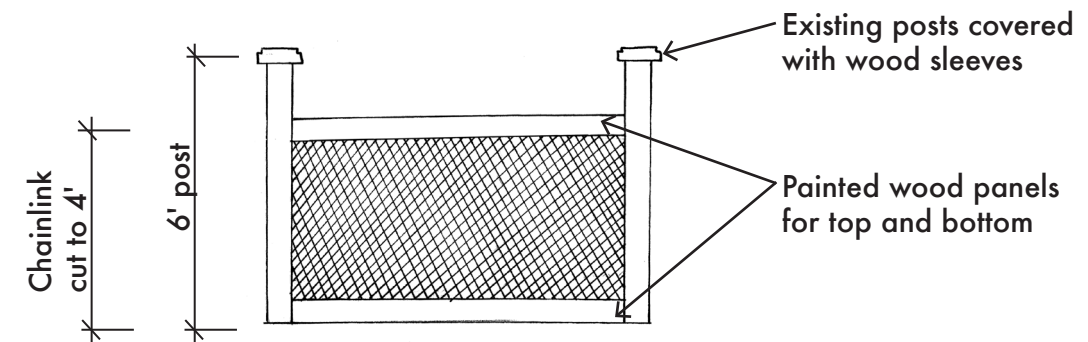

NOTE: Existing posts are covered with wooden sleeves, with chainlink cut to 4 feet. Painted wood panels are added to the top and bottom of chainlink to improve the appearance. Painting the chainlink black may also improve the appearance.

3 WOOD PANELED POST WITH CABLE CONNECTIONS (TYPICAL) NOT TO SCALE

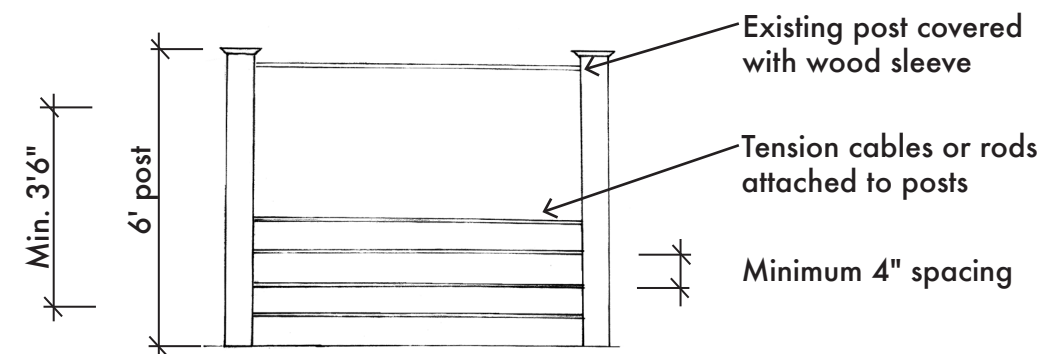

NOTE: Wooden sleeves are added to existing posts with cables or rods attached between. The minimum height for the wires is 3'6" with a minimum spacing of 4".

COST ESTIMATES

The construction of a new parking area and the trails will be the highest cost. These new features are in the river setback and will need to be approved by Massachusetts Department of Environmental Protection. Care needs to be taken with any construction over the existing membrane as it is only one foot below the surface. The estimated cost of construction will range from \$160,000 to \$214,000.

Element	Amount	Units	Low cost	High cost	Low Subtotal	High subtotal
Demolition						
Asphalt removal	800	Sq. yards	\$ 18	\$ 22	\$ 14,400	\$ 17,600
Fence removal	300	linear feet	\$ 20	\$ 22	\$ 6,000	\$ 6,600
Guard rail removal	140	linear feet	\$ 18	\$ 25	\$ 2,520	\$ 3,500
Site Improvements						
Asphalt parking	4,500	Sq. feet	\$ 7	\$ 9	\$ 31,500	\$ 40,500
Bench-granite	9	Each	\$ 1,000	\$ 1,600	\$ 9,000	\$ 14,400
Bench-Quickcrete	2	Each	\$ 800	\$ 1,200	\$ 1,600	\$ 2,400
Boulders	13	Each	\$ 250	\$ 400	\$ 3,250	\$ 5,200
3' Cable fence on Ret.	300	linear feet	\$ 30	\$ 35	\$ 9,000	\$ 10,500
4' Coated chainlink	300	linear feet	\$ 35	\$ 40	\$ 10,500	\$ 12,000
4' wood scalloped fence	300	linear feet	\$ 66	\$ 75	\$ 19,800	\$ 22,500
Rough grading	2,000	Sq. feet	\$ 0.40	\$ 0.60	\$ 800	\$ 1,200
Sidewalk asphalt	3,600	Sq. feet	\$ 6	\$ 9	\$ 21,600	\$ 32,400
Signs	4	Each	\$ 150	\$ 250	\$ 600	\$ 1,000
Stone dust pathways	275	tons	\$ 15	\$ 18	\$ 4,125	\$ 4,950
Landscaping						
Fine Grading	24,700	Sq. feet	\$ 0.20	\$ 0.30	\$ 4,940	\$ 7,410
Seeding	0.75	Acre	\$ 2,000	\$ 4,000	\$ 2,000	\$ 4,000
Seeding undisturbed areas	0.33	Acre	\$ 1,500	\$ 3,000	\$ 1,500	\$ 3,000
Vegetation-shrubs	1	Lump sum	\$ 14,000	\$ 20,000	\$ 14,000	\$ 20,000
Vegetation-trees	10	Each 6-8'	300	\$ 500	\$ 3,000	\$ 5,000
Total Cost					\$ 160,135	\$ 214,160

NOT FOR CONSTRUCTION. THIS DRAWING IS PART OF A STUDENT PROJECT AND IS NOT BASED ON A LEGAL SURVEY.

EMILY BERG, JEFF DAWSON & ALLISON RUSCHP
 THE CONWAY SCHOOL
 GRADUATE PROGRAM IN SUSTAINABLE
 LANDSCAPE PLANNING & DESIGN
 WWW.CSLD.EDU
 SPRING 2014

LEAD MILLS
 CONSERVATION AREA DESIGN
 MARBLEHEAD & SALEM, MA
 485 LAFAYETTE STREET, SALEM, MA 01970

COST ESTIMATES